

Analog Socket Modem

AL3094S, AL4094S Series

Designer's Guide

Version 103

Released 24. Juni 2008



Information provided by xmodus swiss GmbH is believed to be accurate and reliable. However, no responsibility is assumed by xmodus swiss for its use, nor any infringement of patents or other rights of third parties which may result from its use. No license is granted by implication or otherwise under any patent rights of xmodus other than for circuitry embodied in xmodus products. Xmodus swiss reserves the right to change circuitry at any time without notice. This document is subject to change without notice.

Product names or services listed in this publication are for identification purposes only, and may be trademarks or registered trademarks of their respective companies. All other marks mentioned herein are the property of their respective owners.

© 2007 xmodus swiss GmbH
Printed in Switzerland
All Rights Reserved

Table of Contents

1.	INTRODUCTION	5
1.1	Summary	5
1.2	Features.....	6
1.2.1	General Modem Features	6
2.	TECHNICAL OVERVIEW	7
2.1	General Description	7
2.2	Operating Modes	7
2.2.1	Data / Fax Modes.....	7
2.2.2	Synchronous Access Mode (SAM) - Video Conferencing	7
2.2.3	Worldwide Operation.....	8
2.2.4	TAM Mode.....	8
2.2.5	Voice / Speakerphone Mode (only AL4094S)	9
2.3	Commands	9
2.4	Supported Interfaces.....	10
2.4.2	Serial / Indicator Interface:	10
2.4.3	Speaker Interface:.....	10
2.4.4	World Class Line Interface:	10
2.5	Command Set and S-Registers	10
3.	HARDWARE INTERFACE.....	11
3.1	Interface Signals	11
3.2	Signal Description	11
3.3	Firmware ROM	18
3.3	Firmware ROM	18
3.4	DAA Interface	18
3.5	Audio / Speaker Interface	19
3.6	Audio Interface for AL4094S Modem	20
4.	DESIGN CONSIDERATIONS.....	21
4.1	PC Board Layout Guidelines.....	21
4.1.1	General	21
4.1.2	Electromagnetic Interference (EMI) Considerations	22
4.2	Other Considerations	22
4.3	Manufacturing Considerations	23
5.	PACKAGE DIMENSIONS.....	24
6.	SOCKET MODEM APPROVALS.....	25
6.1	Considerations for Telecom Approvals	25
6.1.1	PSTN Connection.....	25
6.2	Considerations for Electrical Safety	25
6.2.1	Conditions for Maintaining Safety Compliance (European Countries).....	25
6.2.2	Power Supply [EN60950-1:2001, 1.6]	26
6.2.3	Clearances and Creepage Distances (EN60950-1:2001)	26
6.3	Considerations for EMC.....	28
6.3.2	Installation in Host Systems (European Countries)	28

List of Figures

Figure 2-1. Typical Serial Block Diagram	10
Figure 3-1. Serial TTL Pinout.....	12
Figure 3-3. Recommended Telephone Line Interface for U.S. Socket Modem	18
Figure 3-5. Sounducer Driver Circuit	19
Figure 3-6. Speaker Driver Circuit	19
Figure 3-7. Audio Interface Circuit.....	20
Figure 5-1. AL4090S Socket Modem Physical Dimensions.....	24

List of Tables

Table 3-1. Serial TTL Signals	12
Table 3-3. Signal Descriptions.....	13
Table 3-3. Signal Descriptions (Cont'd)	14
Table 3-3. Signal Descriptions (Cont'd)	15
Table 3-4. Digital Electrical Characteristics	16
Table 3-5. Analog Electrical Characteristics	17
Table 3-6. Absolute Maximum Ratings	17

1. INTRODUCTION

1.1 Summary

The xmodus AL4094S and AL3094S Socket Modem Family provides the OEM with a complete V.90, V.34 and V.32 bis data/fax/voice/speakerphone modem in a compact socket-mountable module.

The compact size and high level of integration of the Socket Modem minimizes real estate and cost for motherboard and box modem applications. Its low power consumption makes it ideal for portable applications such as pocket modems or laptop, notebook and palmtop computers, and for a wide variety of embedded control applications. The pin compatibility between the full range of AL Series Socket Modems, ISDN and GSM Socket Modems allows upgrading and production configurability without hardware changes.

This designer's guide describes the modem hardware. AT commands and S registers are defined in the AT Command Reference Manual.

As a data modem, the AL4094S and AL3094S Socket Modem can receive data at speeds up to 56kbps and can send data at speeds up to 33.6 kbps. Error correction (V.42 / MNP 2-4) and data compression (V.44, V.42bis, MNP 5) maximize data transfer integrity and boost average throughput up to 115.2 kbps. Non-error-correcting mode is also supported.

As a fax modem, the AL4094S and AL3094S Socket Modem supports Group 3 send and receive rates up to 14.4 kbps and supports Class I/II and T.30 protocols.

The Socket Modem with Voice features uses enhanced Adaptive Differential Pulse Coded Modulation (ADPCM) coding and decoding to support efficient digital storage of voice/audio using 2-bit or 4-bit per sample compression and decompression with a 8000Hz sample rate. This mode supports applications such as digital telephone answering machine (TAM), voice annotation, audio recording and playback to the telephone line.

The AL4094S Socket Modem supports position-independent, full-duplex speakerphone (FDSP) operation using an advanced algorithm that includes both acoustic and line echo cancellation.

In V.22 bis fast connect mode, the modem can connect at 2400 bps with a very short training time, which is very efficient for small data transfers.

1.2 Features

1.2.1 General Modem Features

- Data modem
 - V.90, V.34, V.32bis, V.32, V.22 bis, V.22,V.23, V.21
 - Bell 212A, Bell 103
 - V.44 Data Compression
 - V.42 LAPM and MNP 2-4 error correction
 - V.42 bis and MNP 5 data compression
 - MNP 10EC™ enhanced cellular performance
 - V.250 and V.251 commands
- V.22 bis fast connect
- Analog cellular direct connect using CX20437 Voice Codec
- Fax modem send and receive rates up to 14.4 kbps
 - V.17, V.29, V.27 ter, and V.21 channel 2
 - EIA/TIA 578 Class 1 and T.31 Class 1.0.
- V.80 synchronous access mode supports host-controlled communication protocols with H.324 interface support
- Data/Fax/Voice call discrimination
- Hardware-based modem controller
- Hardware-based digital signal processor (DSP)
- Worldwide operation
 - Complies to TBR21 and other country requirements
 - Call progress, blacklisting
- Telephony/TAM
 - V.253 commands
 - 2-bit and 4-bit Conexant ADPCM, 8-bit linear PCM, and 4-bit IMA coding
 - 8 kHz sample rate
 - Concurrent DTMF and RING detection
- Full-duplex speakerphone (FDSP) mode using CX20437 Voice Codec
 - Microphone and speaker interface
 - Telephone handset or headset interface
 - Acoustic and line echo cancellation
 - Microphone gain and muting
 - Speaker volume control and muting
- Built-in host/DTE interface with speeds up to 115.2 kbps
 - Serial ITU-T V.24 (EIA/TIA-232-E) logical interface (5 Volt Level)
- Direct mode (serial DTE interface)
- Flow control and speed buffering
- Automatic format/speed sensing
- Serial async/sync data; parallel async data
- +5V operation.
- Typical power use
MCD and LSD: 500 mW (Normal Mode)

2. TECHNICAL OVERVIEW

2.1 General Description

Modem operation, including dialing, call progress, telephone line interface, telephone handset interface, voice / speakerphone interface and host interface functions are supported and controlled through the V.250, V.251, and V.253-compatible command set.

2.2 Operating Modes

2.2.1 Data / Fax Modes

In V.34 data modem mode, the modem can operate in 2-wire, full-duplex, asynchronous modes at line rates up to 33.6 kbps. Data modem modes perform complete handshake and data rate negotiations. Using V.34 modulation to optimize modem configuration for line conditions, the modem can connect at the highest data rate that the channel can support from 33600 bps down to 2400 bps with automatic fallback. Automode operation in V.34 is provided in accordance with PN3320 and in V.32 bis in accordance with PN2330. All tone and pattern detection functions required by the applicable ITU or Bell standards are supported.

In V.32 bis data modem mode, the modem can operate at line speeds up to 14.4 kbps.

In V.22 bis fast connect data mode, the modem can connect at 2400 bps with a very short training time, which is very efficient for small data transfers.

In fax modem mode, the modem can operate in 2-wire, half-duplex, synchronous modes and can support Group 3 facsimile send and receive speeds of 14400, 12000, 9600, 7200, 4800, and 2400 bps. Fax data transmission and reception performed by the modem are controlled and monitored through the EIA/TIA-578 Fax Class 1, T.31 Fax Class 1.0 command interface. Full HDLC formatting, zero insertion/deletion, and CRC generation/checking are provided.

2.2.2 Synchronous Access Mode (SAM) - Video Conferencing

V.80 Synchronous Access Mode between the modem and the host/DTE is provided for host-controlled communication protocols, e.g., H.324 video conferencing applications.

Voice-call-first (VCF) before switching to a videophone call is also supported.

2.2.3 Worldwide Operation

The modem operates in TBR21-compliant and other countries. Country-dependant modem parameters for functions such as dialing, carrier transmit level, calling tone, call progress tone detection, answer tone detection, blacklisting, and relay control are programmable. Country code IDs are defined by ITU-T T.35.

The default countries supported are:

Country	Country Code	Country	Country Code	Country	Country Code
Australia	09	India	53	Portugal	8B
Austria	0A	Ireland	57	Singapore	9C
Belgium	0F	Italy	59	South Africa	9F
Brazil	16	Japan	00	Spain	A0
China	26	Korea	61	Sweden	A5
Denmark	31	Malaysia	6C	Switzerland	A6
Finland	3C	Mexico	73	Taiwan	FE
France	3D	Netherlands	7B	United King.	B4
Germany	42	Norway	82	United States	B5
Greece	46	Poland	8A		

2.2.4 TAM Mode

TAM Mode features include 8-bit linear coding at 8 kHz sample rate. Tone detection/generation, call discrimination, and concurrent DTMF detection are also supported. ADPCM (4-bit IMA) coding is also supported to meet Microsoft WHQL logo requirements.

TAM Mode is supported by four submodes:

1. Online Voce Command Mode supports connection to the telephone line or, for S models, a microphone/speaker/handset/headset.
2. Voice Receive Mode supports recording voice or audio data input from the telephone line or, for S models, a microphone/handset/headset.
3. Voice Transmit Mode supports playback of voice or audio data to the telephone line or, for S models, a speaker/handset/headset.
4. Full-duplex Receive and Transmit Mode.

2.2.5 Voice / Speakerphone Mode (only AL4094S)

The AL4094S models include additional telephone handset, external microphone, and external speaker interfaces which support voice and full-duplex speakerphone (FDSP) operation.

Hands-free full-duplex telephone operation is supported in Speakerphone Mode under host control. Speakerphone Mode features an advanced proprietary speakerphone algorithm which supports full-duplex voice conversion with acoustic, line, and handset echo cancellation. Parameters are constantly adjusted to maintain stability with automatic fallback from full-duplex to pseudo-duplex operation. The speakerphone algorithm allows position independent placement of microphone and speaker. The host can separately control volume, muting, and AGC in microphone and speaker channels.

2.3 Commands

The modem supports data modem, fax class 1 modem, fax class 1.0 modem, voice/audio, full-duplex speakerphone (FDSP), MNP 10/MNP 10EC, and V.80 commands, and S Registers in accordance with modem model options. See Doc. No. 4200A for a description of the commands.

Data Modem Operation. Data modem functions operate in response to the AT commands when +FCLASS=0. Default parameters support U.S./Canada operation.

MNP 10 Operation. MNP 10 functions operate in response to MNP 10 commands.

MNP 10EC Operation. MNP 10EC is enabled by the -SEC=1 command.

Fax Modem Operation. Facsimile functions operate in response to fax class 1 commands when +FCLASS=1, fax class 1.0 commands when +FCLASS=1.0.

Voice/Audio Operation. Voice/audio mode functions operate in response to voice/audio commands when +FCLASS=8.

Speakerphone Operation. FDSP functions operate in response to speakerphone commands when +FCLASS=8 and +VSP=1 is selected.

2.4 Supported Interfaces

The major hardware signal interfaces of the AL4094S Series Socket Modem are illustrated in Figure 2-1.

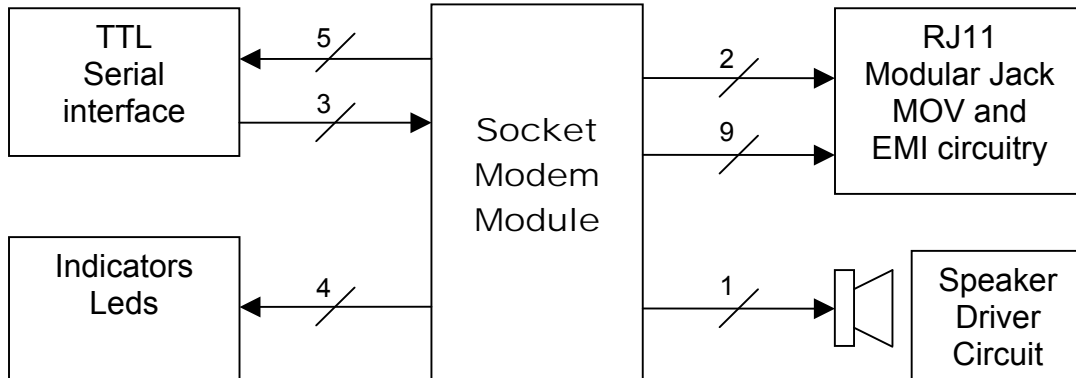

FIGURE 2-1. TYPICAL SERIAL BLOCK DIAGRAM

2.4.2 Serial / Indicator Interface:

DTE serial interface and indicator outputs are supported.

Serial Interface 8-line TTL logic serial interface to the DTE is supported.

LED Indicator Interface Four direct connect LED indicator outputs are supported

2.4.3 Speaker Interface:

A speaker output, controlled by AT commands, is provided for an optional OEM-supplied speaker circuit.

2.4.4 World Class Line Interface:

The World Class Socket Modem includes configurations for use in many countries. These Socket Modems are fully tested for compliance with their respective PTT regulations and are certified for use in these countries.

2.5 Command Set and S-Registers

Modem operation is controlled by AT and S register commands issued by the DTE. Refer to the "AT Commands for the AL4094S Modems Reference Manual" (Order No. 4100A).

3. HARDWARE INTERFACE

3.1 Interface Signals

The Socket Modem pin assignments with DTE serial TTL interface are shown in Figure 3-1 and are listed in Table 3-1.

3.2 Signal Description

The Socket Modem interface signals are described in Table 3-3.

The digital electrical characteristics are listed in Table 3-4.

The analog electrical characteristics are listed in Table 3-5.

Figure 3-1. SERIAL TTL PINOUT

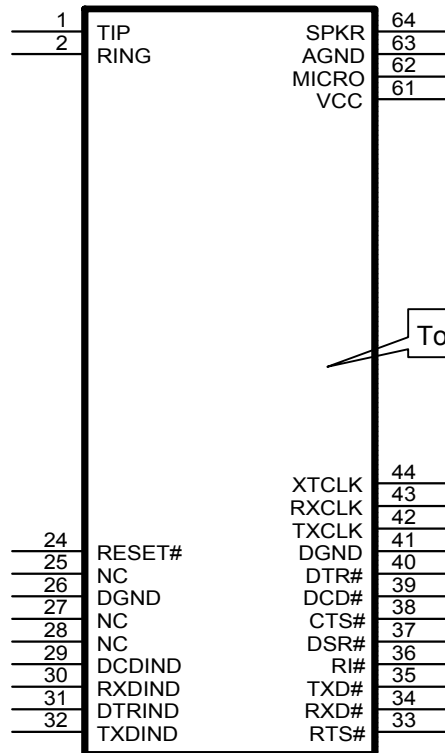

Table 3-1. Serial TTL Signals

PIN	NAME	I/O TYPE	PIN	NAME	I/O TYPE
1	TIP	TEL LINE	33	~RTSTTL	Input
2	RING	TEL LINE	34	~RXDTTL	Output
3	No pin		35	~TXDTTL	Input
4	No pin		36	~RITTL	Output
5	No pin		37	~DSRTTL	Output
6	No pin		38	~CTSTTL	Output
7	No pin		39	~DCDTTL	Output
8	No pin		40	~DTRTTL	Input
9	No pin		41	DGND	GND
10	No pin		42	~TXCLKTTL	Output (AL4094S)
11	No pin		43	~RXCLKTTL	Output (AL4094S)
12	No pin		44	~XTCLKTTL	Input (AL4094S)
13	No pin		45	No pin	
14	No pin		46	No pin	
15	No pin		47	No pin	
16	No pin		48	No pin	
17	No pin		49	No pin	
18	No pin		50	No pin	
19	No pin		51	No pin	
20	No pin		52	No pin	
21	No pin		53	No pin	
22	No pin		54	No pin	
23	No pin		55	No pin	
24	~RESET	Input	56	No pin	
25	No pin		57	No pin	
26	DGND	GND	58	No pin	
27	NC	NC	59	No pin	
28	NC	NC	60	No pin	
29	DCDIND	Output	61	VCC	POWER
30	RXDIND	Output	62	MICRO	Input (AL4094S)
31	DTRIND	Output	63	AGND	Analog GND
32	TXDIND	Output	64	SPEAKER	Output

Table 3-3. Signal Descriptions

Label	I/O Type	Signal Name/Description
VCC	PWR	+5VDC Supply
DGND	GND	Digital Ground Connect to Digital Ground on the interface circuit.
~RES	IC	Modem Reset. The Active Low ~RES input resets the Socket Modem logic and returns the AT command set to the original factory default values and to "stored values" in NVRAM. ~RES is connected to a built-in reset circuit on the Socket Modem. Connect to Ground through an 1nF capacitor to ensure good ESD immunity and to comply with ESD tests according to EN 61000-4-2.
AGND	GND	Analog Ground. Connect to Analog Ground on the interface circuit. AGND and DGND should be connected together on the system board.
TIP	IF	TIP Signal from Telco/PTT
RING	IF	RING Signal from Telco/PTT

Table 3-3. Signal Descriptions (Cont'd)

Label	I/O Type	Signal Name/Description
The Serial interface signals are TTL-level signals.		
~RTSTTL	IB	Request To Send (TTL Active Low). ~RTS is used to condition the local modem for data transmission and, during half-duplex operation, to control the direction of data transmission. On a full-duplex channel, RTS OFF maintains the modem in a non-transmit mode. A non-transmit mode does not imply that all line signals have been removed from the telephone line. RTS OFF may be ignored if the modem is optioned to strap ~CTS ON; this allows the modem to receive from the DTE even though RTS is OFF. RTS input ON causes the modem to transmit data on TXD when ~CTS becomes active.
~RXDTTL	OB	Received Data (TTL Active Low). The modem uses the ~RXD line to send data received from the telephone line to the DTE and to send modem responses to the DTE. Modem responses take priority over incoming data when the two signals are in competition for ~RXD.
~TXDTTL	IA	Transmitted Data (TTL Active Low). The DTE uses the ~TXD line to send data to the modem for transmission over the telephone line or to transmit commands to the modem. The DTE should hold this circuit in the mark state when no data is being transmitted or during intervals between characters.
~CTSTTL	OB	Clear To Send (TTL Active Low). ~CTS is controlled by the modem to indicate whether or not the modem is ready to transmit data. ~CTS ON, together with the ~RTS ON, ~DSR ON, and ~DTR ON (where implemented), indicates to the DTE that signals presented on TXD will be transmitted to the telephone line. ~CTS OFF indicates to the DTE that it should not transfer data across the interface on TXD. ~CTS ON is a response to ~DTR ON and ~RTS, delayed as may be appropriate for the modem to establish a telephone connection. ~CTS output is controlled by the AT&Rn command.
~RITTL	OB	Ring Indicate (TTL Active Low). ~RI output ON (low) indicates the presence of an ON segment of a ring signal on the telephone line. The modem will not go off-hook.
~DSRTTL	OB	Data Set Ready (TTL Active Low). ~DSR indicates modem status to the DTE. ~DSR OFF (high) indicates that the DTE is to disregard all signals appearing on the interchange circuits except Ring Indicator (~RI). ~DSR output is controlled by the AT&Sn command. If the AT&S1 option is selected, ~DSR will come ON in the handshaking state when carrier is detected in the originate mode or when carrier is first sent in the answer mode. In addition, if a test mode is entered (AT&T1, AT&T3, AT&T6-AT&T8), ~DSR will go off while the test is running. ~DSR goes OFF if ~DTR goes OFF. If AT&Q0 and AT&S0 are selected, ~DSR will remain on at all times regardless of the modem's current state.
~DCDTTL	OB	Data Carrier Detect (TTL Active Low). When AT&C0 command is not in effect, ~DCD output is ON when a carrier is detected on the telephone line or OFF when carrier is not detected. ~DCD can be strapped ON using AT&C0 command.

Table 3-3. Signal Descriptions (Cont'd)

Label	I/O Type	Signal Name/Description
The Serial interface signals are TTL-level signals.		
~DTRTTL	IA	Data Terminal Ready (TTL Active Low). The ~DTR input is turned ON (low) by the DTE when the DTE is ready to transmit or receive data. ~DTR ON prepares the modem to be connected to the telephone line, and maintains the connection established by the DTE (manual answering) or internally (automatic answering). ~DTR OFF places the modem in the disconnect state under control of the &Dn and &Qn commands. The effect of ~DTR ON and ~DTR OFF depends on the &Dn and &Qn commands. Automatic answer is enabled when ~DTR is ON if the "Answer Ringcount" selectable option is not set to 0. Regardless of which device is driving ~DTR, the modem will respond to an incoming ring by going off-hook and beginning the handshake sequence. The response of the modem to the ~DTR signal is very slow (up to 10ms) to prevent noise from falsely causing the modem to disconnect from the telephone line.
~RXCLK	OB	Receive Data Clock (only AL4094S). A synchronous Data Clock (RXCLK) is output in synchronous modes. The RXCLK frequency is the data rate (+/- 0.01%) with a duty cycle of 50 +/- 1%. Leave open if not used.
~TXCLK	OB	Transmit Data Clock (only AL4094S). A synchronous Transmit Data Clock (TXCLK) is output in synchronous modes. The TXCLK is the data rate (+/- 0.01%) with a duty cycle of 50 +/-1%. Leave open if not used.
~XTCLK	IA	External Data Clock (only AL4094S). A synchronous External Transmit Data Clock (XTCLK) is input in synchronous modes.

Label	I/O Type	Signal Name/Description
LED driver lines are open-drain inverter-driven (74HCT05) lines with 1.5 K Ω , 1/10W pull-up resistors.		
DCDIND	OG	Active High DCD Status.
RXDIND	OG	Active High RXD Status.
DTRIND	OG	Active High DTR Status.
TXDIND	OG	Active High TXD Status.
Audio Interface		
MICRO	I(DA)	Microphone Voice Input (only AL4094S). MICV is a single-ended microphone input from the analog switch circuit. The input impedance is > 70 k Ω .
SPKR	O(DF)	Speaker Output. SPKR is a single-ended output.
Notes:		
1. I/O types: I(DA) = Analog input (see Table 3-5). O(DD),O(DF) = Analog output (see Table 3-5). IO(DX) = Analog input/output (see Table 3-5).		

Table 3-4. Digital Electrical Characteristics

Parameter	Symbol	Min.	Typ.	Max.	Units	Test Conditions
Input High Voltage	V_{IH}				Vdc	
Type IA		2	-	5.25		
Type IB		2.35	-	5.25		
Type IC		2.35	-	6		
Input Low Voltage	V_{IL}					
Type IA, IB		0	-	0.8		
Type IC		0	-	0.65		
Input Leakage Current ~RESET	I_{IN}	-	-	± 2.5	μ ADC	VIN = 0 to VCC
Output High Voltage	V_{OH}				Vdc	
Type OA		2.4	-	3.3 +/- 0.3		ILOAD = -2 mA
Type OB		-	-	VCC		
Type OC		2.4	-	3.3 +/- 0.3		
Type OG		-	-	VCC		
Output Low Voltage	V_{OL}				Vdc	
Type OA		-	-	0.4		ILOAD = 2 mA
Type OB		-	-	0.4		ILOAD = 24
Type OC		0	-	0.4		mA
Type OG		0.5	-	-		ILOAD = 8 mA
Three-State (OFF) Current	I_{TSI}			± 10	μ ADC	VIN = 0V
Circuit Type						TTL +5V tolerant
Type IA						CMOS +5V tolerant
Type IB						~RESET
Type IC						TTL 3.3V
Type OA						TTL 5V driver
Type OB						LED Driver
Type OC						
Type OG						
Notes:						
1. Test Conditions: VCC = $\pm 5\%$, TA = 0°C to 70°C, VDD = +3.3 +/- 0.3 VDC						
Other = 50 pF + one TTL load.						

Table 3-5. Analog Electrical Characteristics

Name	Type	Characteristic	Value
TELIN	I(DA)	Input Impedance AC Input Voltage Range Reference Voltage	> 70 k Ω 1.1 V P-P +1.35 VDC
TELOUT	O(DD)	Output Impedance AC Output Voltage Range Reference Voltage DC Offset Voltage Minimum Load Maximum Capacitive Load	10 Ω 1.4 V P-P (600 Ω to GND) +1.35 VDC \pm 200 mV 300 Ω 0 μ F
SPKR	O(DF)	Minimum Load Maximum Capacitive Load Output Impedance AC Output Voltage Range Reference Voltage DC Offset Voltage	300 Ω 0.01 μ F 10 Ω 1.4 V P-P +1.35 VDC \pm 20 mV
MICV	I(DA)	Input Impedance AC Input Voltage Range Reference Voltage	> 70 k Ω 1.1 V P-P +1.35 VDC
TIP RING	IF	Ring Detect Sensitivity Ring Detect Peak Current Ring Detect Idle Current Loop Current Ring Equivalency Number (REN)	> 38 V _{RMS} > 100 μ V < 50 nA < 100 mA 1.0 Bel

Table 3-6. Absolute Maximum Ratings

Parameter	Symbol	Min.	Typ.	Max.	Units	Test Condition
Supply Voltage	V _{DD}	-0.3	-	+7.0	Vdc	
Input Voltage	V _{IN}	-0.3	-	+7.0	Vdc	
Nominal Supply Voltage	V _{DD}	4.75	-	5.25	Vdc	
Static Discharge Voltage @ 25°C	V _{ESD}	-	+/- 2500		V	
Operating Temperature Range	T _A	0	-	70	°C	
Storage Temperature Range	T _{STG}	-40	-	+80	°C	
Supply Current Serial Version AL4094S	I _D	-	98	-	mA	
Power Serial Version AL4094S	W	-	0.5	-	W	
Notes:						
Test Conditions: VCC = 5VDC +/- 5%, TA = 25°C						

3.3 Firmware ROM

Socket Modem firmware performs processing of general modem control, command sets, error correction, data compression, MNPEC 10, fax Class 1 and 1.0, fax class 2, voice, audio, RPI, and DTE interface functions depending on the modem model. The Socket Modem firmware is programmed into the on-board ROM.

3.4 DAA Interface

The Socket Modem is configured to be an on-board DAA (World Class DAA).

Provide TIP and RING signals from the telco jack to pins 1 and 2 of the Socket Modem. Only EMI suppression and surge protection components may be used. If other components are used, the PTT certification for these Socket Modems will no longer apply, and recertification will be required.

The recommended telco interface for U.S. and World Class Socket Modems is shown in Figure 3-3.

TIP and RING signal traces are to be no closer than 2.5mm (0.1") from any other traces for European applications. 2.5mm spacing must be used if the host board is to support both U.S. and European Socket Modems.

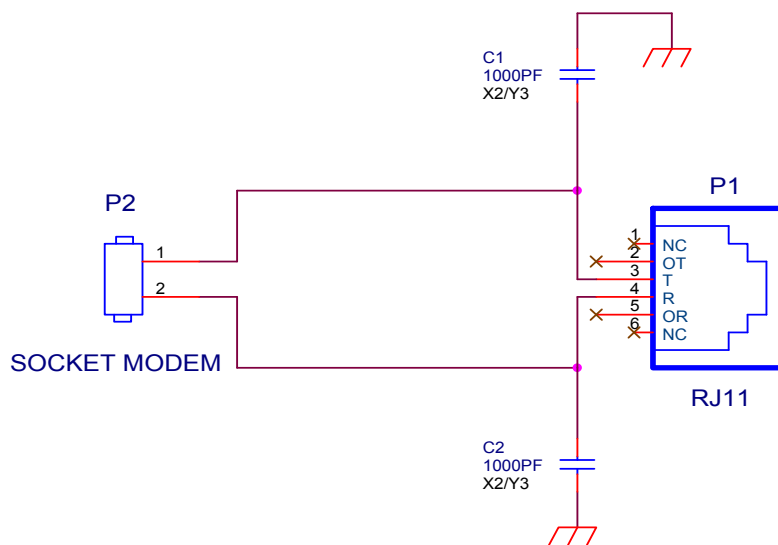

Note:

Meets FCC Part 68 Type A and Type B Surge Requirements (Type A Non-Operational) and additionally meets ITU-T K.21 Surge Requirements

FIGURE 3-3. RECOMMENDED TELEPHONE LINE INTERFACE FOR U.S. AND WORLD CLASS MODEM.

REF	TYPE	Manufacturer	PART No
C1, C2	High Voltage Capacitor / MLCC 1NF, X2 / Y3 Types According EN60950	Johansson Novacap Syfer	302R29W102KV3E LS1808N102K302 1808JA250102KCT

3.5 Audio / Speaker Interface

Audio output is useful for monitoring the modem's call-progress tones and modem system debugging, as well as for full-featured Voice applications. The two audio amplifier circuits shown below are similar in layout but differ in audio quality. The Sounducer circuit is suitable for basic call-progress-tone monitoring, while the speaker circuit is appropriate for Voice applications.

In Figure 3-5, the audio amplifier drives a piezo-electric Sounducer. The SPKR signal from the Socket Modem is fed into an audio amplifier. The 10 μF capacitor between pin 1 and pin 8 of the amplifier bypasses internal circuitry to achieve the maximum gain. The second 10 μF capacitor, between pin 5 of the amplifier and the Sounducer, is used to keep the 2.5 VDC bias of the op amplifier from going into the Sounducer.

In Figure 3-6, the audio amplifier drives an 8 Ω speaker. In this circuit, the amplifier's bypass circuit includes a 760 Ω resistor, and the bias-blocking capacitor changes to 22 μF .

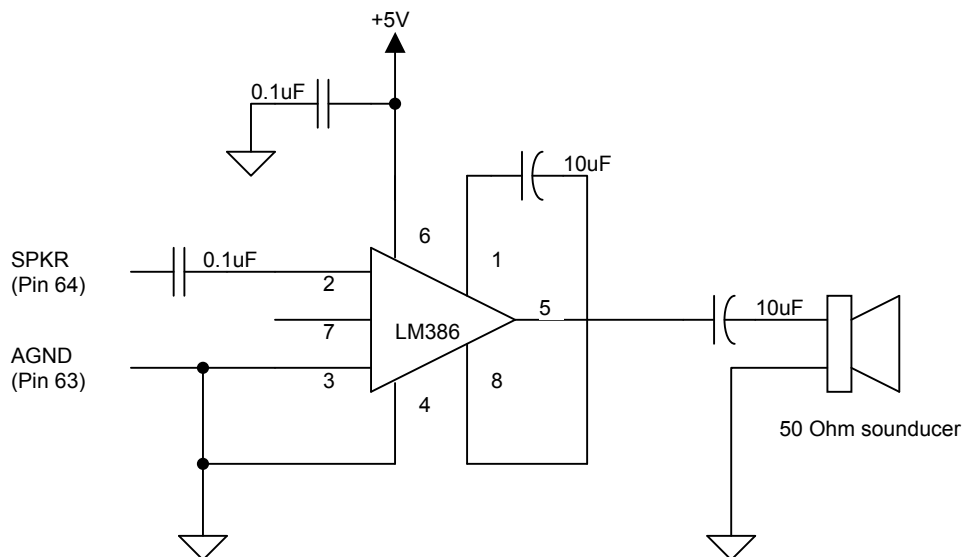

FIGURE 3-5. SOUNDUCER DRIVER CIRCUIT

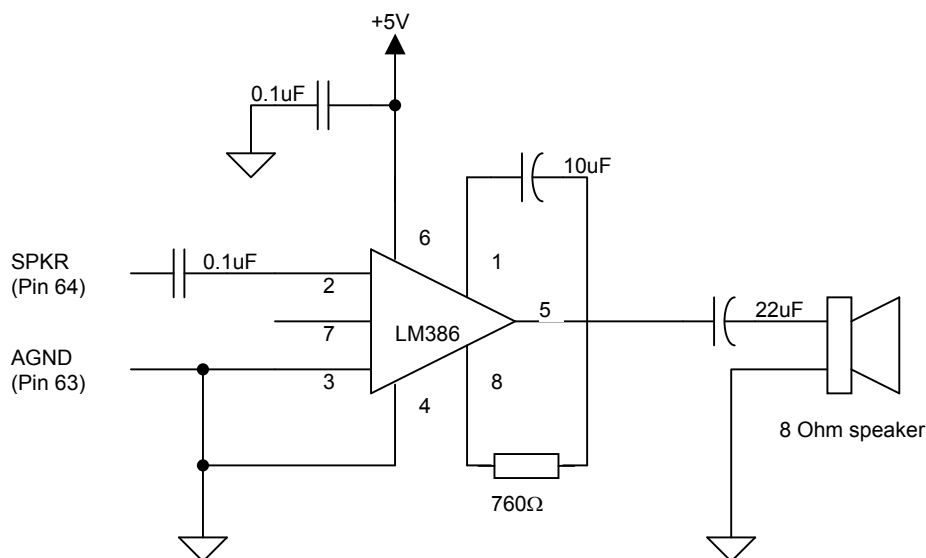

FIGURE 3-6. SPEAKER DRIVER CIRCUIT

3.6 Audio Interface for AL4094S Modem

Figure 3-7 describes the supporting audio circuitry.

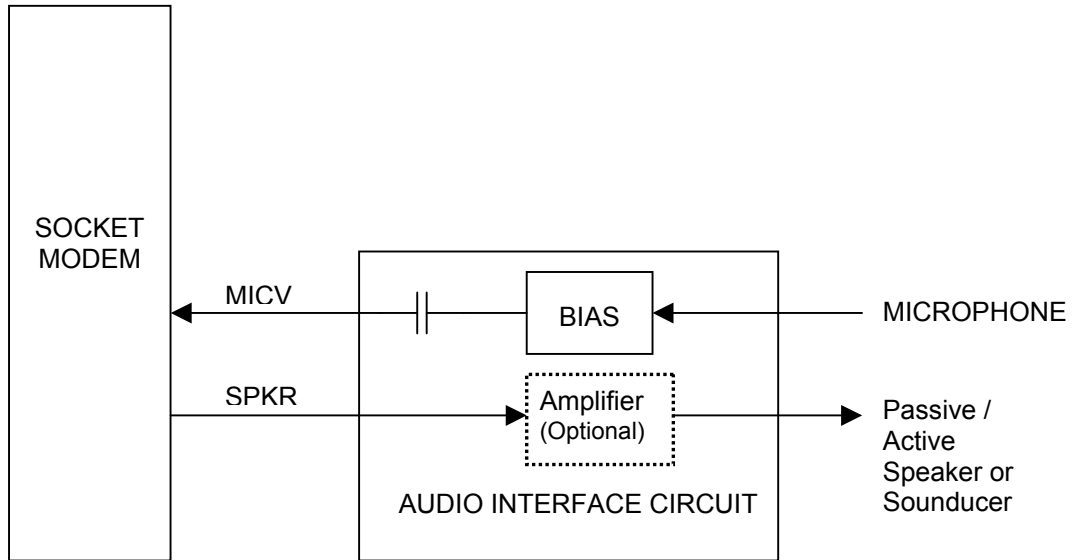

FIGURE 3-7. AUDIO INTERFACE CIRCUIT.

4. DESIGN CONSIDERATIONS

Good engineering practices must be adhered to when designing a printed circuit board (PCB) containing the Socket Modem module. Suppression of noise is essential to the proper operation and performance of the modem itself and for surrounding equipment.

Two aspects of noise in an OEM board design containing the Socket Modem module must be considered: on-board/off-board generated noise that can affect analog signal levels and analog-to-digital conversion (ADC)/digital-to-analog conversion (DAC), and on-board generated noise that can radiate off-board. Both on-board and off-board generated noise that is coupled on-board can affect interfacing signal levels and quality, especially in low level analog signals. Of particular concern is noise in frequency ranges affecting modem performance.

On-board generated electromagnetic interference (EMI) noise that can be radiated or conducted off-board is a separate, but equally important, concern. This noise can affect the operation of surrounding equipment. Most local governing agencies have stringent certification requirements that must be met for use in specific environments.

Proper PC board layout (component placement, signal routing, trace thickness and geometry, etc.), component selection (composition, value, and tolerance), interface connections, and shielding are required for the board design to achieve desired modem performance and to attain EMI certification.

The aspects of proper engineering practices are beyond the scope of this designer's guide. The designer should consult noise suppression techniques described in technical publications and journals, electronics and electrical engineering text books, and component supplier application notes. Seminars addressing noise suppression techniques are often offered by technical and professional associations as well as component suppliers.

4.1 PC Board Layout Guidelines

4.1.1 General

1. In a 2-layer design, provide an adequate ground grid in all unused space around and under components (judiciously near analog components) on both sides of the board, and connect in such a manner as to avoid small islands. A grid is preferred over a plane to improve solderability. Typically, the grid is composed of 0.012 in. traces and 0.012 in. spaces on a 0.025 in. grid. Connect each grid to other grids on the same side at several points and to grids on the opposite side through the board at several points. Connect Socket Modem DGND and AGND pins to the ground grid.
2. As a general rule, route digital signals on the component side of the PCB and the analog signals on the solder side. The sides may be reversed to match particular OEM requirements. Route the digital traces perpendicular to the analog traces to minimize signal cross coupling.
3. Route the modem signals to provide maximum isolation between noise sources and noise sensitive inputs. When layout requirements necessitate routing these signals together, they should be separated by neutral signals.
4. All power and ground traces should be at least 0.05 in. wide.
5. TIP and RING signal traces are to be no closer than 2.5mm (0.1") from any other traces for European applications. 2.5mm spacing must be used if the host board is to support both U.S. and European Socket Modems.
6. If the Socket Modem is mounted flush with the host PCB, the host PCB should be clear of all traces directly underneath the Socket Modem oscillator section. It is strongly suggested that the Socket Modem is mounted at least 0.130 inch above the host board. (See section 4.4)

4.1.2 Electromagnetic Interference (EMI) Considerations

The following guidelines are offered to specifically help minimize EMI generation. Some of these guidelines are the same as, or similar to, the general guidelines but are mentioned again to reinforce their importance.

In order to minimize the contribution of the Socket Modem-based design to EMI, the designer must understand the major sources of EMI and how to reduce them to acceptable levels.

1. Keep traces carrying high frequency signals as short as possible.
2. Provide a good ground plane or grid. In some cases, a multilayer board may be required with full layers for ground and power distribution.
3. Decouple power from ground with decoupling capacitors as close to the Socket Modem module power pins as possible.
4. Eliminate ground loops, which are unexpected current return paths to the power source and ground.
5. Decouple the telephone line cables at the telephone line jacks. Typically, use a combination of series inductors, common mode chokes, and shunt capacitors. Methods to decouple telephone lines are similar to decoupling power lines, however, telephone line decoupling may be more difficult and deserves additional attention. A commonly used design aid is to place footprints for these components and populate as necessary during performance/EMI testing and certification.
6. Decouple the power cord at the power cord interface with decoupling capacitors. Methods to decouple power lines are similar to decoupling telephone lines.
7. Locate high frequency circuits in a separate area to minimize capacitive coupling to other circuits.
8. Locate cables and connectors so as to avoid coupling from high frequency circuits.
10. If a multilayer board design is used, make no cuts in the ground or power planes and be sure the ground plane covers all traces.
11. Minimize the number of through-hole connections on traces carrying high frequency signals.
12. Avoid right angle turns on high frequency traces. Forty-five degree corners are good, however, radius turns are better.
13. On 2-layer boards with no ground grid, provide a shadow ground trace on the opposite side of the board to traces carrying high frequency signals. This will be effective as a high frequency ground return if it is three times the width of the signal traces.
14. Distribute high frequency signals continuously on a single trace rather than several traces radiating from one point.

4.2 Other Considerations

The pins of all Socket Modems are grouped according to function. The DAA interface, Host interface, and LED interface pins are all conveniently arranged, easing the host board layout design. Xmodus swiss has tested each of the AL4094S Socket Modems for compliance with TBR21. The certificates apply only to designs that route TIP and RING (pins 1 and 2) directly to the telco jack. Only specified EMI filtering components are allowed on these two signals as shown in figure 3-3.

4.3 Manufacturing Considerations

The Socket Modem has been designed to be mounted onto the host board in one of two ways.

The first method consists of soldering two 32-pin strip sockets to the host board and inserting the Socket Modem into the sockets. A suggested part number for the 32-pin socket is Sam Tec SMM-132-01-F-S.

The second way is to solder the Socket Modem directly to the host board. The most efficient way to do this is through a wave solder process. The recommended hole size for the Socket Modem pins is 0.036 in. \pm 0.003 in. in diameter. Spacers can be used to hold the Socket Modem vertically in place during the wave solder process. A spacer should be placed on pin 32 and pin 64 of the Socket Modem. A suggested part number for the spacer is BIVAR 938-0.130 for P1(0.310in) option Socket Modems. The spacers can be left on permanently and will not effect operation.

Socket Modems can be put through a water wash process.

5. PACKAGE DIMENSIONS

Package Dimensions are shown in Figure 5-1.

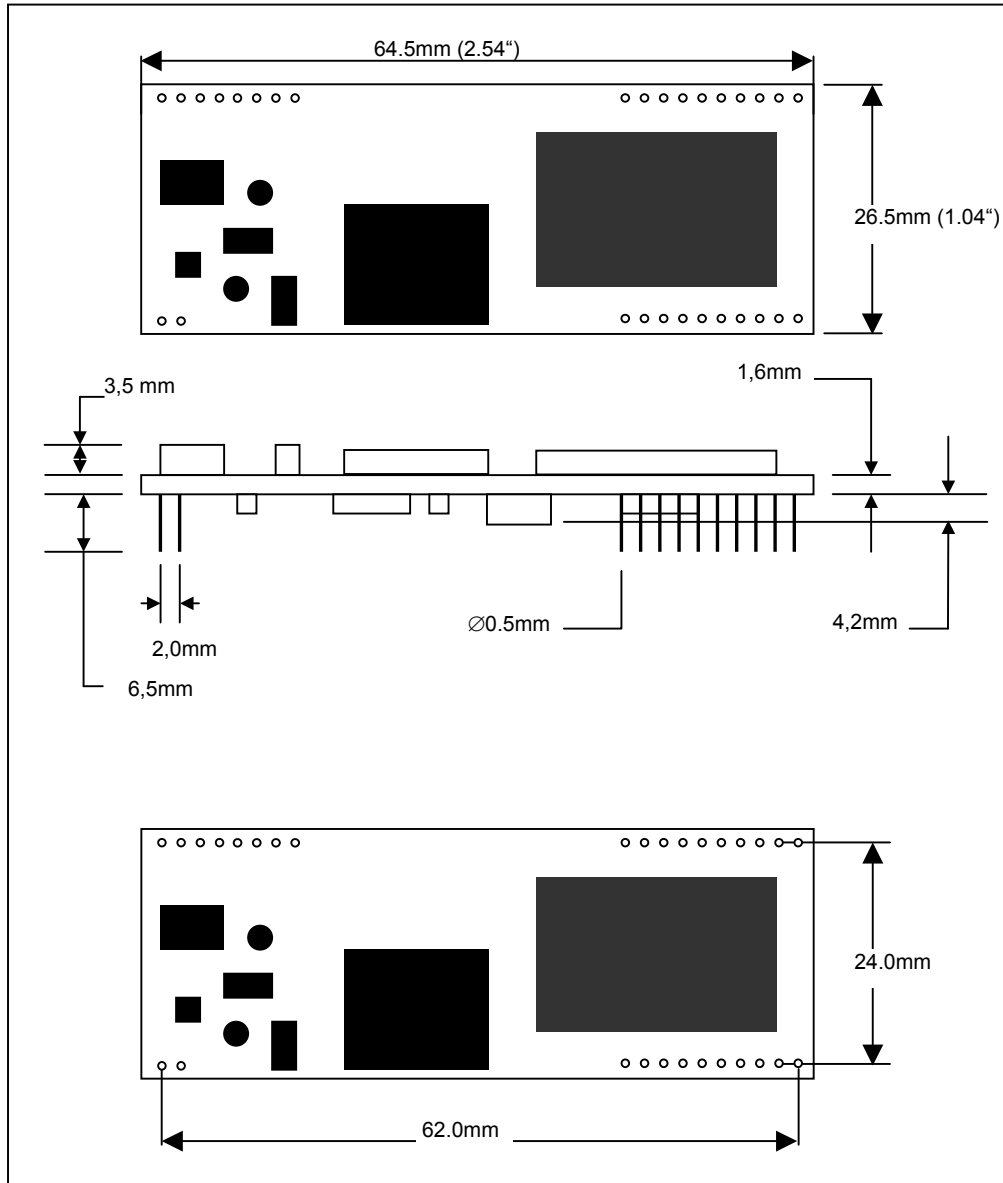

Figure 5-1. AL4094S Socket Modem Physical Dimensions

AL4094S Dimensions	Europe	US
Width	26,5 mm	~1.05"
Height	12.0 mm	~0.5"
Length	64,5 mm	~2.55"
Weight	~ 12 g	~ 0.42 oz
Operating temperature	0...70 °C	32...160 °F
Storage temperature	-10...85 °C	14...185 °F
Humidity	90% non-condensing	90% non-condensing

6. SOCKET MODEM APPROVALS

The Socket Modem module is approved as a host-independent modem card. To maintain type approvals, permits and/or licenses valid, the guidelines described in this document must be followed.

6.1 Considerations for Telecom Approvals

The Socket Modem has been assessed and has been found to comply with the relevant harmonized standards as defined by the European ETSI Directive (ETSI TC-TE).

These standards are: [TBR21 / CTR21](#)

6.1.1 PSTN Connection

The Socket Modem can be connected to the Public Switched Telephone Network (PSTN) either

- a) by using a 2-wire flying cable to connect pins 1 and 2 of the module to an RJ-11 connector which can be assembled in a suitable location of the host system enclosure,
- OR
- b) by providing traces on the host system motherboard for the PSTN connection signals (TIP and RING) between the card and an RJ-11 connector

If connection option a) is used, the cable and its installation inside the host system must be in accordance with the guidelines in IEC950/EN60950 (e.g. the insulation material must withstand electric strength tests as described in section 3.4).

If connection option b) is used, NO additional components except those used for EMI filtering (specified in figure 3-3) must be connected to the TIP and RING signals. Other components not intended for use with this design may affect the network access characteristics of the modem and may therefore invalidate the type approvals, permits and/or licences.

In both cases, for the connection between the host and the PSTN wall connector, a cable with RJ-11 modular jack and an appropriate national plug must be used. Note that in Germany, an F-coded connector/plug must be used (this is one of the two typical plugs used for PSTN connection in Germany, the other type is called N-coded).

6.2 Considerations for Electrical Safety

6.2.1 Conditions for Maintaining Safety Compliance (European Countries)

The Socket Modem has been assessed with respect to electrical safety and has been found to comply with relevant standards as defined by the European Low Voltage Directive (72/23EEC). The particular standard is [EN 60950-1:2001](#).

The card is rated as Class III equipment and it is intended for use in Pollution Degree 2 environments only [see EN60950-1:2001, 2.10.4]. Material Group IIIa or IIIb (Comparative Tracking Index below 400 according to IEC 112, method A) is assumed for any host system PCB that has traces and/or circuitry with TNV potential.

It is assumed that the modem card will only be assembled in a host system unit that complies with IEC60950/EN60950.

Some particular requirements are [see EN60950-1:2001, 2.1.1, 2.2, 2.3, 2.9, 2.10 and 4.7.3.2]:

- the host system must have a compliant fire enclosure (e.g. made of material with flammability class 94V-1 or better).
- the power supply unit of the host system must have double or reinforced insulation.

6.2.2 Power Supply [EN60950-1:2001, 1.6]

Before installing the Socket Modem in a host system, the installer must ensure that the power drawn by the card, together with the host and any auxiliary cards drawing power from the host, is within the rating of the host power supply unit.

The Socket Modem's power consumption is typically 0.5 W (+5.0 Vdc).

6.2.3 Clearances and Creepage Distances (EN60950-1:2001)

Clearances, Creepage Distances and Distances through Insulation [EN60950-1:2001, 2.10.3 and 2.10.4]

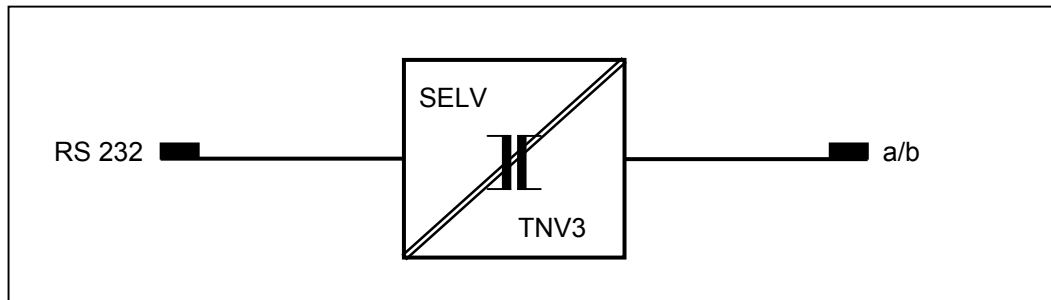

This card must be installed such that with the exception of the connections to the host, clearance and creepage distances shown in the table below are maintained between

- a) the TNV3 area of the card (the DAA) and conductive parts of other assemblies inside the host,
- b) if applicable, the PSTN connection traces (TIP and RING) routed through the host system motherboard and any other conductive area (i.e. traces, through holes, SMD pads, copper areas, etc.) on that motherboard,

which use or generate a voltage shown in the table below (**values only for secondary circuits**):

EN60950:2000 Table 2K / 2L		
Clearance (mm)	Creepage (mm)	Voltage used or Generated by Host or Other cards
1.0	1.5 (2.4)	Up to 125 Vrms or Vdc
2.0	2.5 (4.0)	Up to 250 Vrms or Vdc
2.5	3.2 (5.0)	Up to 300 Vrms or Vdc

The larger distances shown in brackets applies for Pollution Degree 3 environments (where the local environment within the host is subject to conductive pollution or dry non-conductive pollution, which could become conductive due to expected condensation).

The same clearance and creepage distances also apply between TNV3 areas of the card and earth connections inside the host system.

Clearance and creepage between primary (mains) and secondary circuits according EN 60950-1:2001, clause 2.10.3.2 table 2H and clause 2.10.4 table 2L.

Minimum distances between primary and secondary circuits (f.g. for mains voltage 230 V_{AC}):

Clearance = 4 mm

Creepage = 5 mm

Failure to maintain these minimum distances would invalidate the approval.

NOTE: For a host or other expansion cards fitted in the host using or generating voltages greater than 300 V (rms or dc), *advice from a competent telecommunications safety engineer must be obtained.*

If these clearance and creepage distances cannot be provided inside the host due to space limitations, a dielectric material may be used as a physical insulation barrier. The dielectric material used in this insulation must have a thickness of at least 0.4mm.

After installation (or implementation) of the Socket Modem inside a host system, it is recommended that a competent telecommunications safety engineer inspects the complete system to ensure that safety compliance is maintained.

(TNV = Telecommunications Network Voltages)

6.3 Considerations for EMC

6.3.1 EMC Compliance (European Countries)

The Socket Modem has been assessed with respect to emission of and immunity to electromagnetic disturbances and has been found to comply with the relevant harmonized standards as defined by the European EMC Directive (89/336/EEC).

These standards are:

- Generic emission standards which refers to
EN 55022:1998 +A1:2000, Class B
- Generic immunity standards which refers to
EN 55024:1998 +A1:2001
EN 61000-6-2:2001 (industrial environment)

6.3.2 Installation in Host Systems (European Countries)

It is assumed that the Socket Modem will only assembled in host systems that comply with the EMC Directive.

As per definition of the EMC Directive, the card and its host system will constitute an "installation" similar to e.g. a PC card modem installed in a personal computer. Therefore, if the host system complies with the EMC Directive, there should be no need for verifying continued compliance of the complete system.

However, note that it is the responsibility of the professional installer of Socket Modem to ensure that the complete system placed on the market complies with the Directive.