

Analog Socket Modem

AL4200S, AL4200S-3V Series

Designer's Guide

Version 105

Released 14. Dezember 2007



Information provided by xmodus swiss GmbH is believed to be accurate and reliable. However, no responsibility is assumed by xmodus swiss for its use, nor any infringement of patents or other rights of third parties which may result from its use. No license is granted by implication or otherwise under any patent rights of xmodus swiss other than for circuitry embodied in xmodus products. Xmodus swiss reserves the right to change circuitry at any time without notice. This document is subject to change without notice.

Product names or services listed in this publication are for identification purposes only, and may be trademarks or registered trademarks of their respective companies. All other marks mentioned herein are the property of their respective owners.

© 2007 xmodus swiss GmbH
Printed in Switzerland
All Rights Reserved

Table of Contents

1.	INTRODUCTION	5
1.1	Overview	5
1.2	Product Options	5
1.3	General Modem Features	6
1.4	Applications	6
2.	TECHNICAL OVERVIEW	7
2.1	General Description	7
2.2	Operating Modes	7
2.3	Worldwide Operation	7
2.3	TAM Mode	8
2.4	Voice / Speakerphone Mode	8
2.5	Audio Codec Features	8
2.6	Commands	9
2.6	Supported Interfaces	10
2.6.1	Serial Interface:	10
2.6.2	Speaker Interface:	10
2.6.3	World Class Line Interface:	10
2.7	Command Set and S-Registers	10
3.	HARDWARE INTERFACE	11
3.1	Modem Hardware Pins and Signals	11
3.1.1	Phone Line Interface	11
3.1.2	Call Progress Speaker Interface	11
3.1.3	Serial DTE Interface and Indicator Outputs	11
3.1.4	External Reset Input	11
3.2	Modem Pin Assignments and Signal Definitions	11
3.3	Firmware ROM	18
3.4	DAA Interface	18
3.5	Call Progress Speaker Interface	19
3.6	Audio Interface	20
3.6.1	Analog Audio Input Channels	20
3.6.2	Analog Audio Output Channels	20
3.7	Reset Interface	21
3.7.1	Recommended Reset Circuit	21
4.	DESIGN CONSIDERATIONS	22
4.1	PC Board Layout Guidelines	22
4.1.1	General	22
4.1.2	Electromagnetic Interference (EMI) Considerations	23
4.2	Other Considerations	24
4.3	Manufacturing Considerations	24
5.	PACKAGE DIMENSIONS	25
6.	SOCKET MODEM APPROVALS	26
6.1	Considerations for Telecom Approvals	26
6.1.1	PSTN Connection	26
6.2	Considerations for Electrical Safety	26
6.2.1	Conditions for Maintaining Safety Compliance (European Countries)	26
6.2.2	Power Supply [EN60950-1:2001, 1.6]	27
6.2.3	Clearances, Creepage Distances [EN60950-1:2001, 2.10.3 and 2.10.4]	27
6.3	Considerations for EMC	28
6.3.2	Installation in Host Systems (European Countries)	29

List of Figures

FIGURE 2-1. TYPICAL SERIAL BLOCK DIAGRAM	10
FIGURE 3-1. SERIAL TTL PINOUT	12
FIGURE 3-3. RECOMMENDED 2-WIRE TELEPHONE LINE INTERFACE	18
FIGURE 3-4. RECOMMENDED 4-WIRE TELEPHONE LINE INTERFACE	18
FIGURE 3-5. SOUNDUCER DRIVER CIRCUIT	19
FIGURE 3-6. SPEAKER DRIVER CIRCUIT	19
FIGURE 3-7. SINGLE-ENDED HANDSET RECOMMENDED CIRCUIT.	20
FIGURE 3-8. DIFFERENTIAL SPEAKER/MICROPHONE RECOMMENDED CIRCUIT.	20
FIGURE 5-1. AL4200S SOCKET MODEM PHYSICAL DIMENSIONS	25

List of Tables

TABLE 3-1. SERIAL TTL SIGNALS.....	12
TABLE 3-2. SIGNAL DESCRIPTIONS.....	13
TABLE 3-3. SIGNAL DESCRIPTIONS.....	14
TABLE 3-4. DIGITAL ELECTRICAL CHARACTERISTICS	15
TABLE 3-5. ANALOG ELECTRICAL CHARACTERISTICS	16
TABLE 3-5. ANALOG ELECTRICAL CHARACTERISTICS	17
TABLE 3-6. ABSOLUTE MAXIMUM RATINGS.....	17

1. INTRODUCTION

1.1 Overview

The xmodus AL4200S Socket Modem Family provides the OEM with a complete V.90, V.34 and V.32 bis data/fax/voice/speakerphone modem in a compact socket-mountable module.

The compact size and high level of integration of the Socket Modem minimizes real estate and cost for motherboard and box modem applications. Its low power consumption makes it ideal for many applications such as embedded control systems, POS terminals, remote diagnostics, data collection, remote maintenance, web-enabled devices and other embedded applications. The pin compatibility between the full range of Analog, ISDN and GSM Socket Modems allows upgrading and production configurability without hardware changes.

This designer's guide describes the modem hardware. AT commands and S registers are defined in the AT Command Reference Manual.

As a data modem, the AL4200S Socket Modems can receive data at speeds up to 56kbps and can send data at speeds up to 33.6 kbps. Error correction (V.42 / MNP 2-4) and data compression (V.44, V.42bis, MNP 5) maximize data transfer integrity and boost average throughput up to 115.2 kbps. Non-error-correcting mode is also supported.

PSTN as well as Leased-Line copper wire is supported as the transmit medium.

As a fax modem, the AL4200S Socket Modems supports Group 3 send and receive rates up to 14.4 kbps (G3-Fax) and supports Class 1, Class 2 and 2.0 protocols.

The voice features uses voice coding with 8-bit linear A-law / u-law, 16-bit, ADPCM and G.729 to support efficient digital storage of voice / audio samples using compression and decompression with 7200, 8000 and 11025 sampling rates. This mode supports applications such as digital telephone answering machine (TAM), voice annotation, audio recording and playback to the telephone line.

The AL4200S Socket Modems supports position-independent, full-duplex speakerphone (FDSP) operation using an advanced algorithm that includes both acoustic and line echo cancellation.

1.2 Product Options

	AL4200S	AL4200SL
Fax Class 2 / 2.0	✓	✓
Leased Line (2-wire)		✓
V.92 56K Data Modem	✓	✓
Voice Codec / Speakerphone	✓	
Hook Relay (4 pole phone line interface)	✓	
3V / 5V Versions	✓	✓
Ext. temp. option -25° to +70°	✓	✓

1.3 General Modem Features

- Data modem
 - V.92, V.34bis, V.32bis, V.32, V.22 bis, V.22, V.23, V.21
 - Bell 212A, Bell 103
 - V.44 Data Compression
 - V.42 LAPM and MNP 2-4 error correction
 - V.42 bis and MNP 5 data compression
 - V.250 and V.251 commands
- Analog cellular direct connect using Voice Codec
- Fax modem send and receive rates up to 33.6 kbps
 - V.17, V.29, V.27 ter, and V.21 channel 2
 - EIA/TIA 578 Class 1 (T.31)
 - EIA/TIA 578 Class 2 / 2.0 (T.32)
- Data/Fax/Voice call discrimination
- Hardware-based modem controller
- Hardware-based digital signal processor (DSP)
- Worldwide operation
 - Complies to TBR21 and other country requirements
 - Call progress, blacklisting
- Telephony/TAM
 - V.253 commands
 - 8-bit linear A-law / u-law, 16-bit, ADPCM and G.729 coding
 - 7200, 8000 and 11025Hz sampling rates.
 - Concurrent DTMF and ring detection
- Full-duplex speakerphone (FDSP) mode using Voice Codec
 - Microphone and speaker interface
 - Telephone handset or headset interface
 - Acoustic and line echo cancellation
 - Microphone gain and muting
 - Speaker volume control and muting
- Differential input/output for quality audio circuits
- Single-ended input for handset connection
- Built-in host/DTE interface with speeds up to 115.2 kbps
 - Serial ITU-T V.24 (EIA/TIA-232-E) logical interface (3V/5V Volt Level)
- Direct mode (serial DTE interface)
- Flow control and speed buffering
- Automatic format/speed sensing
- Serial async data
- Hook Relay with 4-wire Line Interface.
- Leased-Line copper wire supported (2-wire)
- Extended temperature (-25° to +70° C) available as option.
- +3V and +5V operation.
- Typical power use: 750 mW (Normal Mode)

1.4 Applications

- Embedded Systems
- M2M applications
- Alarm devices
- Point of sales terminals
- Remote monitoring and data collection

2. TECHNICAL OVERVIEW

2.1 General Description

Modem operation, including dialing, call progress, telephone line interface, telephone handset interface, voice / speakerphone interface and host interface functions are supported and controlled through the V.250, V.251, and V.253-compatible command set.

2.2 Operating Modes

In V.34 data modem mode, the modem can operate in 2-wire, full-duplex, asynchronous modes at line rates up to 33.6 kbps. Data modem modes perform complete handshake and data rate negotiations. Using V.34 modulation to optimize modem configuration for line conditions, the modem can connect at the highest data rate that the channel can support from 33600 bps down to 2400 bps with automatic fallback. Automode operation in V.34 is provided in accordance with PN3320 and in V.32 bis in accordance with PN2330. All tone and pattern detection functions required by the applicable ITU or Bell standards are supported.

In V.32 bis data modem mode, the modem can operate at line speeds up to 14.4 kbps.

In fax modem mode, the modem can operate in 2-wire, half-duplex, synchronous modes and can support Group 3 facsimile send and receive speeds of 14400, 12000, 9600, 7200, 4800, and 2400 bps. Fax data transmission and reception performed by the modem are controlled and monitored through the EIA/TIA-578 Fax Class 1, T.32 Fax Class 2 and 2.0 command interface. Full HDLC formatting, zero insertion/deletion, and CRC generation/checking are provided.

2.3 Worldwide Operation

The modem operates in TBR21-compliant and other countries. Country-dependant modem parameters for functions such as dialing, carrier transmit level, calling tone, call progress tone detection, answer tone detection, blacklisting, caller ID, and relay control are programmable. Country code IDs are defined by ITU-T T.35.

The default countries supported you will find in the "AT Command Manual", Table 207 on page 111.

2.3 TAM Mode

TAM Mode features include 8-bit linear A-law / u-law, 16-bit, ADPCM and G.729 coding at 7200, 8000 and 11025Hz sampling rates. Tone detection/generation, call discrimination, and concurrent DTMF detection are also supported. TAM Mode is supported by four submodes:

1. Online Voice Command Mode supports connection to the telephone line or a microphone/speaker and handset/headset.
2. Voice Receive Mode supports recording voice or audio data input from the telephone line or a microphone and handset/headset.
3. Voice Transmit Mode supports playback of voice or audio data to the telephone line or a speaker and handset/headset.
4. Full-duplex Receive and Transmit Mode.

2.4 Voice / Speakerphone Mode

The AL4200S models include additional telephone handset, external microphone, and external speaker interfaces which support voice and full-duplex speakerphone (FDSP) operation.

Hands-free full-duplex telephone operation is supported in Speakerphone Mode under host control. Speakerphone Mode features an advanced proprietary speakerphone algorithm which supports full-duplex voice conversion with acoustic, line, and handset echo cancellation. Parameters are constantly adjusted to maintain stability with automatic fallback from full-duplex to pseudo-duplex operation. The speakerphone algorithm allows position independent placement of microphone and speaker. The host can separately control volume, muting, and AGC in microphone and speaker channels.

2.5 Audio Codec Features

Audio-band 16-bit linear codec:

- SNR is greater than 65 dB for voice band.
- Single-ended input/output for handset is greater than 40 dB.
- Differential input/output for speaker/microphone is greater than 65 dB
- Sample rates from 7.2 kHz to 11.25 kHz
- Single-ended input for handset connection
- Differential input/output for quality audio circuits
- Sigma-delta (S-D) based codec

2.6 Commands

The modem supports data modem, fax class 1 modem, fax class 2 and 2.0 modem, voice/audio, full-duplex speakerphone (FDSP) and S Registers in accordance with modem model options. See the "AT Command Manual" for a description of the commands.

Data Modem Operation. Data modem functions operate in response to the AT commands when +FCLASS=0. Default parameters support U.S./Canada operation.

Fax Modem Operation. Facsimile functions operate in response to fax class 1 commands when +FCLASS=1. Fax class 2 commands when +FCLASS=2, fax class 2.0 commands when +FCLASS=2.0.

Voice/Audio Operation. Voice/audio mode functions operate in response to voice/audio commands when +FCLASS=8.

Speakerphone Operation. FDSP functions operate in response to speakerphone commands when +FCLASS=8 and +VSP=1 is selected.

2.6 Supported Interfaces

The major hardware signal interfaces of the AL4200S Series Socket Modem are illustrated in Figure 2-1.

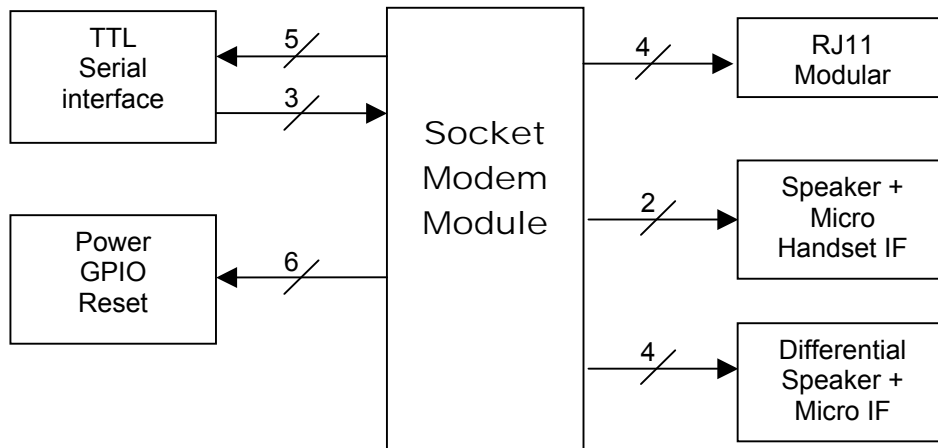

FIGURE 2-1. TYPICAL SERIAL BLOCK DIAGRAM

2.6.1 Serial Interface:

DTE serial interface and indicator outputs are supported.

Serial Interface: 8-line TTL logic serial interface to the DTE is supported.

2.6.2 Speaker Interface:

A speaker output, controlled by AT commands, is provided for an optional OEM-supplied speaker circuit.

2.6.3 World Class Line Interface:

The World Class Socket Modem includes configurations for use in many countries. These Socket Modems are fully tested for compliance with their respective PTT regulations and are certified for use in these countries.

2.7 Command Set and S-Registers

Modem operation is controlled by AT and S register commands issued by the DTE. Refer to the "AT Commands for the AL4200S Modems Reference Manual".

3. HARDWARE INTERFACE

3.1 Modem Hardware Pins and Signals

3.1.1 Phone Line Interface

The phone-line interface signals are:

- TIP
- RING
- TIP2 (TIP return is optional)
- RING2 (RING return is optional)

3.1.2 Call Progress Speaker Interface

The call progress speaker interface signal is:

- Digital speaker output = SPKR (Pin 64)

DSPKOUT is a square wave output in Data/Fax mode used for call progress or carrier monitoring. This output can be optionally connected to a low-cost on-board speaker, e.g., a sounducer, or to an analog speaker circuit.

3.1.3 Serial DTE Interface and Indicator Outputs

The supported DTE interface signals are:

- Serial Transmit Data input (TXD#)
- Serial Receive Data output line (RXD#)
- Clear to Send output (CTS#)
- Received Line Signal Detector (DCD#)
- Ring Indicator (RI#)
- Data Terminal Ready control input (DTR#)
- Request to Send control input (RTS#)

3.1.4 External Reset Input

The supported reset input interface signals are:

- External Reset Input (RESET#)

3.2 Modem Pin Assignments and Signal Definitions

The socket modem DIL-64 hardware interface signals are shown by major interface in Figure 3-1, are shown by pin number in Figure 3-2, and are listed by pin number in Table 3-1.

Modem hardware interface signals are defined in Table 3-2.

I/O types are defined in Table 3-3.

DC electrical characteristics are listed in Table 3-4.

Figure 3-1. SERIAL TTL PINOUT

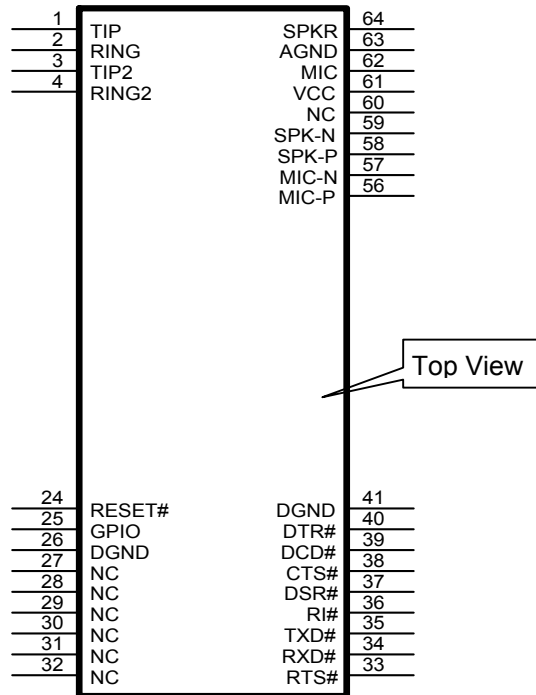

Table 3-1. Serial TTL Signals

PIN	NAME	I/O TYPE	PIN	NAME	I/O TYPE
1	TIP	TEL LINE	33	~RTSTTL	Input
2	RING	TEL LINE	34	~RXDTTL	Output
3	TIP2	TIP RETURN	35	~TXDTTL	Input
4	RING2	RING RETURN	36	~RITTL	Output
5	No pin		37	~DSRTTL	Output
6	No pin		38	~CTSTTL	Output
7	No pin		39	~DCDTTL	Output
8	No pin		40	~DTRTTL	Input
9	No pin		41	DGND	DIGITAL GND
10	No pin		42	No pin	
11	No pin		43	No pin	
12	No pin		44	No pin	
13	No pin		45	No pin	
14	No pin		46	No pin	
15	No pin		47	No pin	
16	No pin		48	No pin	
17	No pin		49	No pin	
18	No pin		50	No pin	
19	No pin		51	No pin	
20	No pin		52	No pin	
21	No pin		53	No pin	
22	No pin		54	No pin	
23	No pin		55	No pin	
24	~RESET	Input	56	MIC-P	Micro+ Input
25	GPIO	Input	57	MIC-N	Micro- Input
26	DGND	DIGITAL GND	58	SPK-P	Speaker+ Out
27	NC	NC	59	SPK-N	Speaker- Out
28	NC	NC	60	NC	
29	NC	NC	61	VCC	POWER
30	NC	NC	62	MIC	Micro Input
31	NC	NC	63	AGND	Audio Ground
32	NC	NC	64	SPKR	Speaker Output

Table 3-2. Signal Descriptions

LABEL	I/O TYPE	SIGNAL NAME / DESCRIPTION
VCC	PWR	3.3V (3V models) or +5V Power
DGND	GND	Digital Ground Connect to Digital Ground on the interface circuit.
~RES	IC/OC	Modem Reset. Open collector input/output. Drive only with open-collector circuit. The Active Low ~RES input resets the Socket Modem logic and returns the AT command set to the original factory default values and to "stored values" in NVRAM. ~RES is connected to a built-in reset circuit on the Socket Modem.
TIP	IF	TIP Signal from Telco/PTT
TIP	IF	TIP Signal from Telco/PTT
TIP2	IF	TIP Return from Hook Relay (optional)
RING2	IF	RING Return from Hook Relay (optional)
GPIO	IA	GPIO Input. (not used)

LABEL	I/O TYPE	SIGNAL NAME / DESCRIPTION SERIAL INTERFACE
~RTSTTL	IA	Request To Send (TTL Active Low). ~RTS is used to condition the local modem for data transmission. On a full-duplex channel, RTS OFF maintains the modem in a non-transmit mode. A non-transmit mode does not imply that all line signals have been removed from the telephone line. RTS OFF may be ignored if the modem is optioned to strap ~CTS ON; this allows the modem to receive from the DTE even though RTS is OFF. RTS input ON causes the modem to transmit data on TXD when ~CTS becomes active.
~RXDTTL	OA	Received Data (TTL Active Low). The modem uses the ~RXD line to send data received from the telephone line to the DTE and to send modem responses to the DTE. Modem responses take priority over incoming data when the two signals are in competition for ~RXD.
~TXDTTL	IA	Transmitted Data (TTL Active Low). The DTE uses the ~TXD line to send data to the modem for transmission over the telephone line or to transmit commands to the modem. The DTE should hold this circuit in the mark state when no data is being transmitted or during intervals between characters.
~CTSTTL	OA	Clear To Send (TTL Active Low). ~CTS is controlled by the modem to indicate whether or not the modem is ready to transmit data. ~CTS ON, together with the ~RTS ON, ~DSR ON, and ~DTR ON (where implemented), indicates to the DTE that signals presented on TXD will be transmitted to the telephone line. ~CTS OFF indicates to the DTE that it should not transfer data across the interface on TXD. ~CTS ON is a response to ~DTR ON and ~RTS, delayed as may be appropriate for the modem to establish a telephone connection. ~CTS output is controlled by the AT&Rn command.

Table 3-3. Signal Descriptions

LABEL	I/O TYPE	SIGNAL NAME / DESCRIPTION SERIAL INTERFACE
~RITTTL	OA	Ring Indicate (TTL Active Low). ~RI output ON (low) indicates the presence of an ON segment of a ring signal on the telephone line. The modem will not go off-hook.
~DSRTTL	OA	Data Set Ready (TTL Active Low). ~DSR indicates modem status to the DTE. ~DSR OFF (high) indicates that the DTE is to disregard all signals appearing on the interchange circuits except Ring Indicator (~RI). ~DSR output is controlled by the AT&Sn command. If the AT&S1 option is selected, ~DSR will come ON in the handshaking state when carrier is detected in the originate mode or when carrier is first sent in the answer mode. ~DSR goes OFF if ~DTR goes OFF. If AT&Q0 and AT&S0 are selected, ~DSR will remain on at all times regardless of the modem's current state.
~DCDTTL	OA	Data Carrier Detect (TTL Active Low). When AT&C0 command is not in effect, ~DCD output is ON when a carrier is detected on the telephone line or OFF when carrier is not detected. ~DCD can be strapped ON using AT&C0 command.
~DTRTTL	IA	Data Terminal Ready (TTL Active Low). The ~DTR input is turned ON (low) by the DTE when the DTE is ready to transmit or receive data. ~DTR ON prepares the modem to be connected to the telephone line, and maintains the connection established by the DTE (manual answering) or internally (automatic answering). ~DTR OFF places the modem in the disconnect state under control of the &Dn and &Qn commands. The effect of ~DTR ON and ~DTR OFF depends on the &Dn and &Qn commands. Automatic answer is enabled when ~DTR is ON if the "Answer Ringcount" selectable option is not set to 0. Regardless of which device is driving ~DTR, the modem will respond to an incoming ring by going off-hook and beginning the handshake sequence. The response of the modem to the ~DTR signal is very slow (up to 10ms) to prevent noise from falsely causing the modem to disconnect from the telephone line.

LABEL	I/O TYPE	SIGNAL NAME / DESCRIPTION AUDIO INTERFACE
MIC	AINA	Microphone Voice Input. MIC is a single-ended microphone input from the analog switch circuit.
SPKR	AOUTA	Speaker Output. SPKR is a single-ended output from the analog switch circuit. (Call progress speaker output)
MIC-P	AINB	Microphone Voice Input. MIC-P is a differential microphone input from the analog switch circuit.
MIC-N	AINB	Microphone Voice Input. MIC-N is a differential microphone input from the analog switch circuit.
SPK-P	AOUTB	Speaker Output. SPK-P is a differential speaker output from the analog switch circuit.
SPK-N	AOUTB	Speaker Output. SPK-N is a differential speaker output from the analog switch circuit.
Notes: AINA, AINB = Analog input (see Table 3-5). AOUTA, AOUTB = Analog output (see Table 3-5).		

Table 3-4. Digital Electrical Characteristics

PARAMETER	SYMBOL	MIN.	TYP.	MAX.	UNITS	TEST CONDITIONS
Input High Voltage Type IA Inputs are 5V tolerant	V_{IH}	$0.7 \times V_{DD33}$	-	$V_{DD33} + 0.3$	Vdc	
Input Low Voltage Type IA	V_{IL}	-0.3	-	$0.3 \times V_{DD33}$	Vdc	
Output High Voltage Type OA	V_{OH}	$V_{DD33} - 0.7$ $V_{DD33} - 0.2$	- -	- -	Vdc	$I_{OH} = -1.8\text{mA}$ $I_{OH} = -50\mu\text{A}$
Output Low Voltage Type OA	V_{OL}	- -	- -	0.4 0.2	Vdc	$I_{OL} = 1.8\text{mA}$ $I_{OL} = 50\mu\text{A}$
Three-State (OFF) Current	I_{TSL}			± 10	μADC	$V_{IN} = 0\text{V}$
Circuit Type Type IA Type OA						TTL +5V tolerant TTL 3.3V
Notes:						
1. Test Conditions: $V_{DD33} = +3.3 \pm 0.3 \text{ VDC}$, $T_A = 0^\circ\text{C}$ to 70°C						

Table 3-5. Analog Electrical Characteristics

TYPE	PARAMETER	CONDITIONS	VALUE
AINA (MIC)	Source Impedance	ac-coupled with a 0.2 μ F cap	1k Ω - 3 k Ω
	Input Impedance	With ac-coupled 150 mVp-p input, PGA gain = 21 dB	20 k Ω min
	Gain	493 mVrms input, 1015 Hz, PGA gain = 0 dB	0 dBm \pm 0.5 dB
	Full Scale	Vin = 3.14 dBm0, PGA gain = 0 dBm	2.0 Vp-p typical
	Total Harmonic Distortion	Vin = 2.5 dBm0, PGA gain = 0 dB Vin = 0 dBm0, PGA gain = 0 dB Vin = -40 dBm0, PGA gain = 0 dB	-40 dB -50 dB -45 dB
	Idle Channel Noise	PGA = 12 dB	20 dBmC0 max.
	Power Supply Rejection Ratio	300 Hz—10 kHz	50 dB min

TYPE	PARAMETER	CONDITIONS	VALUE
AINB (MIC-P MIC-N)	Source Impedance	ac-coupled with 0.2 μ F cap	1k Ω - 3 k Ω
	Input Impedance	With ac-coupled 40 mVp-p input, PGA gain = 0 dB	12 k Ω - 30 k Ω
	Preamp Gain	0 dBm0 = 9.85 mVrms, PGA gain = 6 dB Output measured relative to measured AINA encoder milliwatt response	28 dB \pm 1.5 dB
	Full Scale	Vin = 3.14 dBm0, PGA gain = 6 dB	40 mVp-p typical
	Idle Channel Noise	PGA gain = 12 dB	26 dBmC0 max.
	Total Harmonic Distortion	Vin = 2.5 dBm0, PGA gain = 0 dB Vin = 0 dBm0, PGA gain = 0 dB Vin = -40 dBm0, PGA gain = 0 dB	-40 dB -50 dB -45 dB

TYPE	PARAMETER	CONDITIONS	VALUE
AOUTA	VOUT (gain)	PCM = 0 dBm0 Measured relative to AOUTA decoder milliwatt response	493 mVrms \pm 0.5 dB
	VOUT (full scale)	PCM = 3.14 dBm0 RL = 150 CLmax = 300 pF	2.00 Vp-p typical
	Load Resistance	ac coupled	135 Ω min
	Total Harmonic Distortion	PCM = 2.5 dBm0 PCM = 0 dBm0 PCM = -40 dBm0	-40 dB -55 dB -45 dB
	Idle Channel Noise	PCM = idle code	8 dBmC0 max.

Table 3-5. Analog Electrical Characteristics

TYPE	PARAMETER	CONDITIONS	VALUE
AOUTB	VOUT (gain)	PCM = 0 dBm0 Measured relative to AOUTA decoder milliwatt response	6 dB ± 0.25dB
	VOUT (full scale)	PCM = 3.14 dBm0 RL = 16 Clmax = 300 pF	4.00 Vp-p typical (125 mW at 16 Ω)
	Load Resistance	Differential	15 Ω min.
	Total Harmonic Distortion	Vout = 3.6 Vp-p* Vout = 3.2 Vp-p* PCM = -40 dBm0 PCM = 0 dBm0	-30 dB -40 dB -45 dB -55 dB
	Idle Channel Noise	PCM = idle code	8 dBmC0 max.

Table 3-6. Absolute Maximum Ratings

PARAMETER	SYMBOL	MIN.	TYP.	MAX.	UNITS	CONDITIONS
Supply Voltage	V _{DD}				Vdc	
5V Models		-0.3	-	+ 7.0		
3V Models		0	-	+ 3.6		
Input Voltage	V _{IN}	-0.3	-	+7.0	Vdc	
Nominal Supply Voltage	V _{DD}				Vdc	
5V Models		4.75	5.0	5.25		
3V Models		3.135	3.3	3.465		
Static Discharge Voltage @ 25°C	V _{ESD}	-	+/- 2500		V	
Operating Temperature Range	T _A	0	-	70	°C	
Supply Current	I _D				mA	
AL4200S Idle		-	125	130		Idle mode.
AL4200SL Idle		-	88	90		
AL4200S Online		-	140	145		Online mode.
AL4200SL Online		-	96	98		
AL4200S FSDP		-	188	190		Speakerphone mode with an 8Ω speaker connected
		-	-	-		
		-	-	-		

Notes:

Test Conditions: VCC = 5VDC +/- 5%, TA = 25°C,

3.3 Firmware ROM

Socket Modem firmware performs processing of general modem control, command sets, error correction, data compression, fax Class 1 and 2.0, voice, audio, RPI, and DTE interface functions depending on the modem model. The Socket Modem firmware is programmed into the on-board flash.

3.4 DAA Interface

The Socket Modem is configured to be an on-board DAA (World Class DAA). Provide TIP and RING signals from the telco jack to pins 1 and 2 of the Socket Modem. Only EMI suppression components may be used. If other components are used, the PTT certification for these Socket Modems will no longer apply, and recertification will be required. The recommended telco interface for World Class Socket Modems is shown in Figure 3-4.

TIP and RING signal traces are to be no closer than 2.5mm (0.1") from any other traces for European applications. 2.5mm spacing must be used if the host board is to support both U.S. and European Socket Modems.

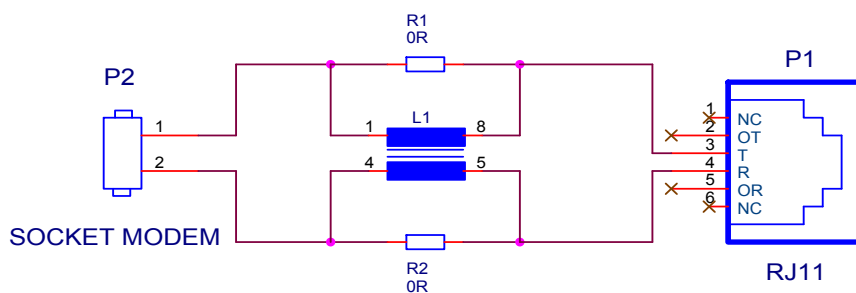

Figure 3-3. Recommended 2-Wire Telephone Line Interface

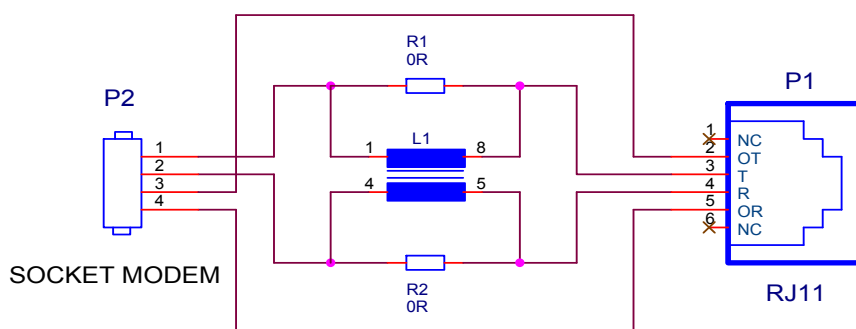

Figure 3-4. Recommended 4-wire Telephone Line Interface

The common mode choke L1 is optional in both Figures 3.3 and 3.4. The need depends on the characteristics of the target hardware. The need for this choke must be evaluated at EMV measurement (conducted emission) of the final product. If not used populate R1, R2.

3.5 Call Progress Speaker Interface

Audio output is useful for monitoring the modem's call-progress tones and modem system debugging, as well as for full-featured Voice applications. The two audio amplifier circuits shown below are similar in layout but differ in audio quality. The Sounducer circuit is suitable for basic call-progress-tone monitoring, while the speaker circuit is appropriate for Voice applications.

In Figure 3-5, the audio amplifier drives a piezo-electric Sounducer. The SPKR signal from the Socket Modem is fed into an audio amplifier. The 10 μF capacitor between pin 1 and pin 8 of the amplifier bypasses internal circuitry to achieve the maximum gain. The second 10 μF capacitor, between pin 5 of the amplifier and the Sounducer, is used to keep the 2.5 VDC bias of the op amplifier from going into the Sounducer.

In Figure 3-6, the audio amplifier drives an 8 Ω speaker. In this circuit, the amplifier's bypass circuit includes a 760 Ω resistor, and the bias-blocking capacitor changes to 22 μF .

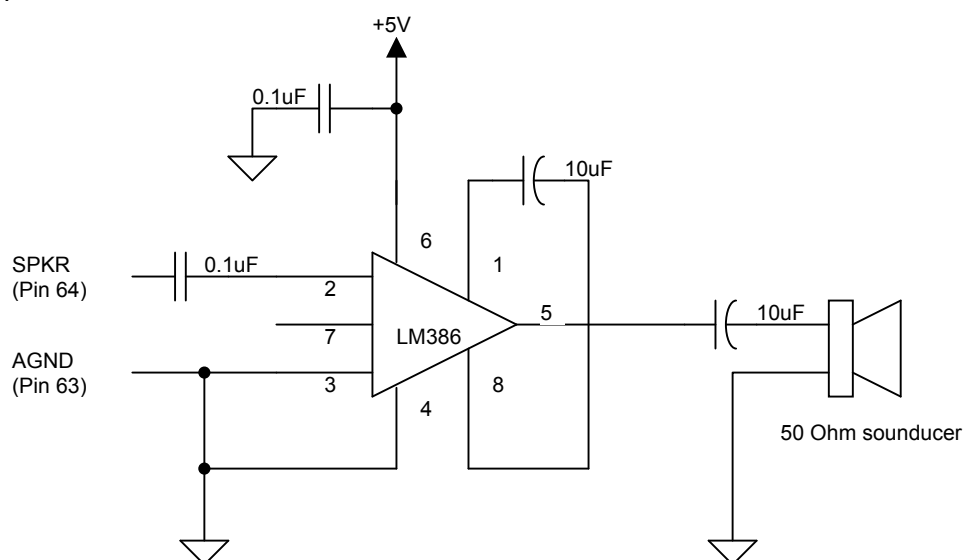

FIGURE 3-5. SOUNDUCER DRIVER CIRCUIT

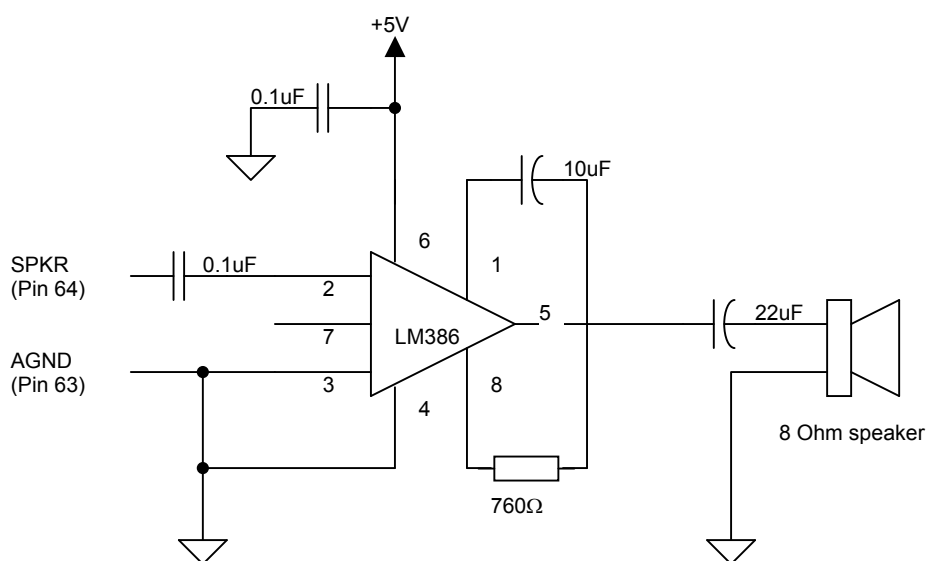

FIGURE 3-6. SPEAKER DRIVER CIRCUIT

3.6 Audio Interface

3.6.1 Analog Audio Input Channels

The integrated Codec circuit contains two audio analog inputs. There is a single-ended input (AINA) for connection to a standard business telephone handset receiver and a differential input pair (AINBP, AINBN) for connection to a microphone. The differential input is directly connected to an amplifier. The programmable gain amplifier is adjustable from 0 dB to 21 dB in 3 dB steps (see AT commands). The signal output from the programmable gain amplifier is then connected to the audio codec block to be digitized. The input signals to AINB-P and AINB-N are ac-coupled to their codec inputs by an 0.2 μF capacitor on the socket modem board. The maximum signal input to the codec is specified in table 3.5. If the user sets the amplification to a value that would produce a larger signal than specified, the audio codec will saturate and clip the input waveform.

3.6.2 Analog Audio Output Channels

The codec contains two analog audio output ports. There is a single-ended output signal (AOUTA) for connection to the speaker of a standard 150 business telephone handset and a differential speaker driver output pair (AOUTB) for connection to a 16 Ω speaker. Both outputs receive their analog signals from the single-channel audio codec block that converts the digital input stream to analog signals. The maximum signal from the codec is 2.0 Vp-p. The AOUTA signal has a maximum 2.0 Vp-p signal swing. It should maintain a midlevel bias to prevent load noises when the driver is re-enabled. The speaker outputs (AOUTB) each have 2 Vp-p signal swing. Since these outputs are of opposite polarity, the differential signal output is 4 Vp-p. This is a 6 dB effective amplification of the codec output signal. The signals should be biased such that, when power is re-enabled, no audible noises occur. The differential speaker output driver does not have to produce a full 4 Vp-p signal without distortion. Signals above 4 Vp-p measured from AOUTB may be in the nonlinear range of the differential amplifier and exhibit a flattening or clipping characteristic at the output.

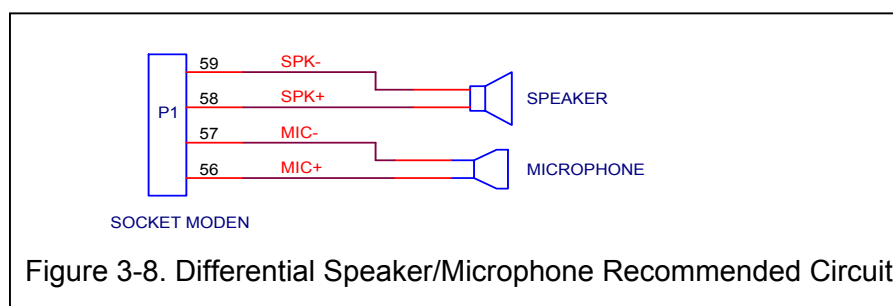
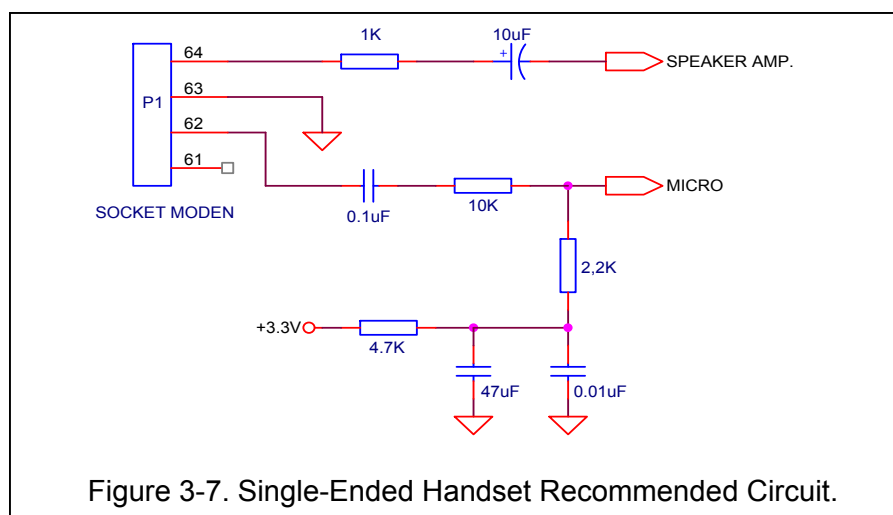

3.7 Reset Interface

3.7.1 Recommended Reset Circuit

This signal is used to force a reset procedure by providing low level during at least 100uS. This signal has to be considered as an emergency reset only. A reset procedure is already driven by an internal hardware during the power-up sequence.

If no external reset is necessary this input can be left open. If used (emergency reset), it has to be driven by an open collector or an open drain.

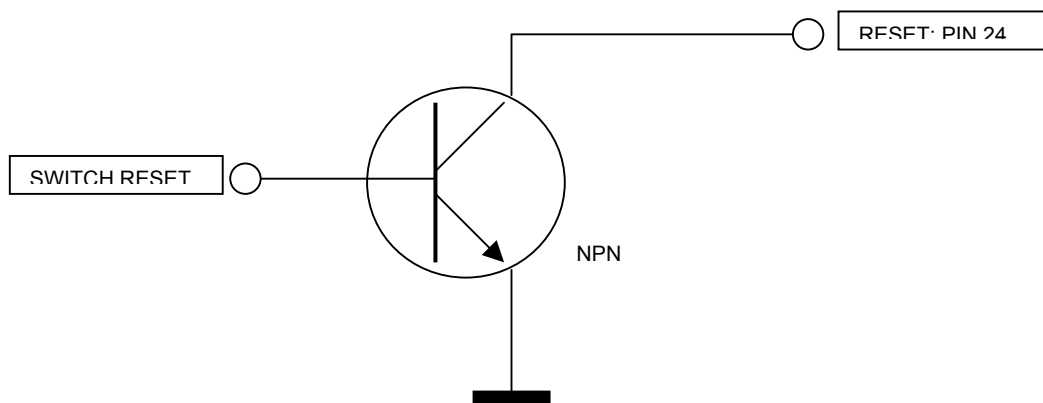

Switch Reset	Reset (Pin 24)	Reset Status
1	0	Active
0	1	Inactive

Additional comments on RESET:

The reset process is activated either by the external Reset signal OR by an internal signal (coming from the internal RESET generator). This automatic reset is activated at power-up.

The module remains in reset mode as long as the reset signal is held low. As soon as the reset is complete, the AT interface answers "OK" to the application.

4. DESIGN CONSIDERATIONS

Good engineering practices must be adhered to when designing a printed circuit board (PCB) containing the Socket Modem module. Suppression of noise is essential to the proper operation and performance of the modem itself and for surrounding equipment.

Two aspects of noise in an OEM board design containing the Socket Modem module must be considered: on-board/off-board generated noise that can affect analog signal levels and analog-to-digital conversion (ADC)/digital-to-analog conversion (DAC), and on-board generated noise that can radiate off-board. Both on-board and off-board generated noise that is coupled on-board can affect interfacing signal levels and quality, especially in low level analog signals. Of particular concern is noise in frequency ranges affecting modem performance.

On-board generated electromagnetic interference (EMI) noise that can be radiated or conducted off-board is a separate, but equally important, concern. This noise can affect the operation of surrounding equipment. Most local governing agencies have stringent certification requirements that must be met for use in specific environments.

Proper PC board layout (component placement, signal routing, trace thickness and geometry, etc.), component selection (composition, value, and tolerance), interface connections, and shielding are required for the board design to achieve desired modem performance and to attain EMI certification.

4.1 PC Board Layout Guidelines

4.1.1 General

1. In a 2-layer design, provide an adequate ground grid in all unused space around and under components (judiciously near analog components) on both sides of the board, and connect in such a manner as to avoid small islands. A grid is preferred over a plane to improve solderability. Typically, the grid is composed of 0.012 in. traces and 0.012 in. spaces on a 0.025 in. grid. Connect each grid to other grids on the same side at several points and to grids on the opposite side through the board at several points. Connect Socket Modem DGND and AGND pins to the ground grid. All power and ground traces should be at least 0.05 in. wide.
2. In a 4-layer design, provide an adequate ground plane covering the entire board. Socket Modem DGND and AGND pins are not tied together on the Socket Modem.
3. As a general rule, route digital signals on the component side of the PCB and the analog signals on the solder side. The sides may be reversed to match particular OEM requirements. Route the digital traces perpendicular to the analog traces to minimize signal cross coupling.
4. Route the modem signals to provide maximum isolation between noise sources and noise sensitive inputs. When layout requirements necessitate routing these signals together, they should be separated by neutral signals.
5. TIP and RING signal traces are to be no closer than 2.5mm (0.1") from any other traces for European applications. 2.5mm spacing must be used if the host board is to support both U.S. and European Socket Modems.

4.1.2 Electromagnetic Interference (EMI) Considerations

The following guidelines are offered to specifically help minimize EMI generation. Some of these guidelines are the same as, or similar to, the general guidelines but are mentioned again to reinforce their importance.

In order to minimize the contribution of the Socket Modem-based design to EMI, the designer must understand the major sources of EMI and how to reduce them to acceptable levels.

1. Keep traces carrying high frequency signals as short as possible.
2. Provide a good ground plane or grid. In some cases, a multilayer board may be required with full layers for ground and power distribution.
3. Decouple power from ground with decoupling capacitors as close to the Socket Modem module power pins as possible.
4. Eliminate ground loops, which are unexpected current return paths to the power source and ground.
5. Decouple the telephone line cables at the telephone line jacks. Typically, use a combination of series inductors, common mode chokes, and shunt capacitors. Methods to decouple telephone lines are similar to decoupling power lines, however, telephone line decoupling may be more difficult and deserves additional attention. A commonly used design aid is to place footprints for these components and populate as necessary during performance/EMI testing and certification.
6. Decouple the power cord at the power cord interface with decoupling capacitors. Methods to decouple power lines are similar to decoupling telephone lines.
7. Locate high frequency circuits in a separate area to minimize capacitive coupling to other circuits.
8. Locate cables and connectors so as to avoid coupling from high frequency circuits.
10. If a multilayer board design is used, make no cuts in the ground or power planes and be sure the ground plane covers all traces.
11. Minimize the number of through-hole connections on traces carrying high frequency signals.
12. Avoid right angle turns on high frequency traces. Forty-five degree corners are good, however, radius turns are better
13. On 2-layer boards with no ground grid, provide a shadow ground trace on the opposite side of the board to traces carrying high frequency signals. This will be effective as a high frequency ground return if it is three times the width of the signal traces.
14. Distribute high frequency signals continuously on a single trace rather than several traces radiating from one point.

4.2 Other Considerations

The pins of all Socket Modems are grouped according to function. The DAA interface, Host interface, and Audio interface pins are all conveniently arranged, easing the host board layout design.

Xmodus has tested each of the AL4200S series Socket Modems for compliance with TBR21. The certificates apply only to designs that route TIP and RING (pins 1 and 2) directly to the telco jack. Only specified EMI filtering components are allowed on these two signals as shown in figure 3-3.

4.3 Manufacturing Considerations

The Socket Modem has been designed to be mounted onto the host board in one of two ways.

The first method consists of soldering two 32-pin strip sockets to the host board and inserting the Socket Modem into the sockets. A suggested part number for the 32-pin socket is Sam Tec SMM-132-01-F-S.

The second way is to solder the Socket Modem directly to the host board. The most efficient way to do this is through a wave solder process. The recommended hole size for the Socket Modem pins is 0.036 in. \pm 0.003 in. in diameter. Spacers can be used to hold the Socket Modem vertically in place during the wave solder process. A spacer should be placed on pin 32 and pin 64 of the Socket Modem. A suggested part number for the spacer is BIVAR 938-0.130 for P1(0.310in) option Socket Modems. The spacers can be left on permanently and will not effect operation.

Socket Modems can be put through a water wash process.

5. PACKAGE DIMENSIONS

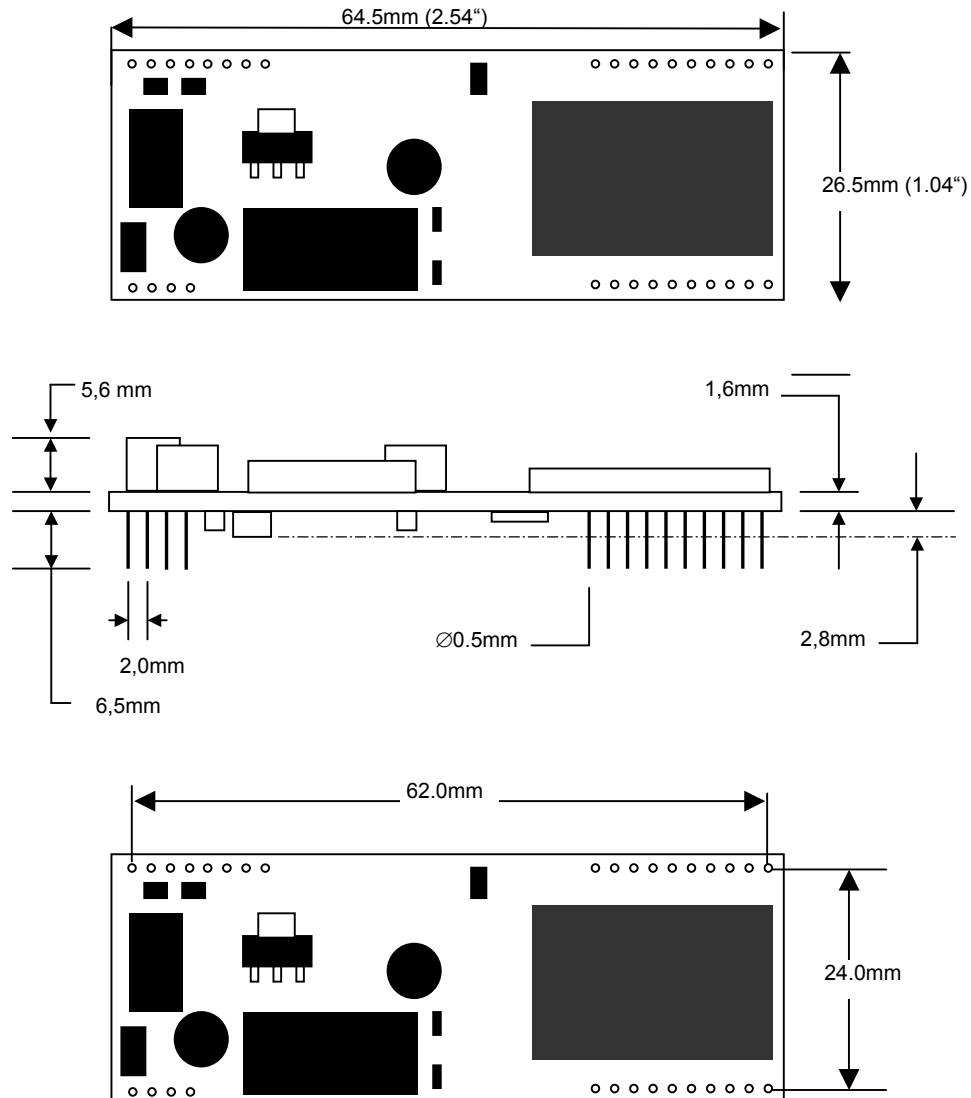

Figure 5-1. AL4200S Socket Modem Physical Dimensions

AL4200S Dimensions	Europe	US
Width	26,5 mm	~1.05"
Height	14.1 mm	~0.55"
Length	64,5 mm	~2.55"
Weight	~ 12 g	~ 0.42 oz
Operating temperature	0...70 °C	32...160 °F
Storage temperature	-10...85 °C	14...185 °F
Humidity	90% non-condensing	90% non-condensing

6. SOCKET MODEM APPROVALS

The Socket Modem module is approved as a host-independent modem card. To maintain type approvals, permits and/or licenses valid, the guidelines described in this document must be followed.

6.1 Considerations for Telecom Approvals

The Socket Modem has been assessed and has been found to comply with the relevant harmonized standards as defined by the European ETSI Directive (ETSI TC-TE).

These standards are: [TBR21 / CTR21](#)

6.1.1 PSTN Connection

The Socket Modem can be connected to the Public Switched Telephone Network (PSTN) either

- a) by using a 2-wire flying cable to connect pins 1 and 2 of the module to an RJ-11 connector which can be assembled in a suitable location of the host system enclosure,
OR
- b) by providing traces on the host system motherboard for the PSTN connection signals (TIP and RING) between the card and an RJ-11 connector

If connection option a) is used, the cable and its installation inside the host system must be in accordance with the guidelines in IEC950/EN60950 (e.g. the insulation material must withstand electric strength tests as described in section 3.4).

If connection option b) is used, NO additional components except those used for EMI filtering (specified in figure 3-3) must be connected to the TIP and RING signals. Other components not intended for use with this design may affect the network access characteristics of the modem and may therefore invalidate the type approvals, permits and/or licences.

In both cases, for the connection between the host and the PSTN wall connector, a cable with RJ-11 modular jack and an appropriate national plug must be used. Note that in Germany, an F-coded connector/plug must be used (this is one of the two typical plugs used for PSTN connection in Germany, the other type is called N-coded).

6.2 Considerations for Electrical Safety

6.2.1 Conditions for Maintaining Safety Compliance (European Countries)

The Socket Modem has been assessed with respect to electrical safety and has been found to comply with relevant standards as defined by the European Low Voltage Directive (72/23EEC). The particular standard is [EN 60950-1:2001](#).

The card is rated as Class III equipment and it is intended for use in Pollution Degree 2 environments only [see EN60950-1:2001, 2.10.4]. Material Group IIIa or IIIb (Comparative Tracking Index below 400 according to IEC 112, method A) is assumed for any host system PCB that has traces and/or circuitry with TNV potential.

It is assumed that the modem card will only be assembled in a host system unit that complies with IEC60950/EN60950.

Some particular requirements are [see EN60950-1:2001, 2.1.1, 2.2, 2.3, 2.9, 2.10 and 4.7.3.2]:

- the host system must have a compliant fire enclosure (e.g. made of material with flammability class 94V-1 or better).
- the power supply unit of the host system must have double or reinforced insulation.

6.2.2 Power Supply [EN60950-1:2001, 1.6]

Before installing the Socket Modem in a host system, the installer must ensure that the power drawn by the card, together with the host and any auxiliary cards drawing power from the host, is within the rating of the host power supply unit.

The Socket Modem's power consumption is typically 0.8 W (+5.0 Vdc).

6.2.3 Clearances, Creepage Distances [EN60950-1:2001, 2.10.3 and 2.10.4]

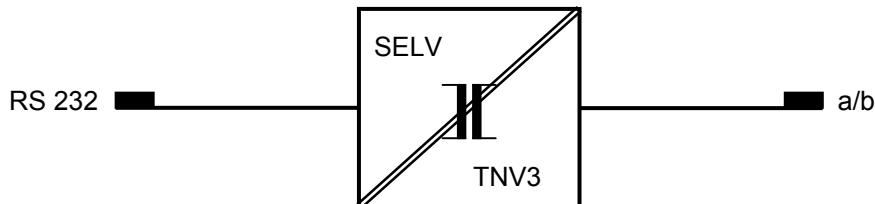

This card must be installed such that with the exception of the connections to the host, clearance and creepage distances shown in the table below are maintained between

- a) the TNV3 area of the card (the DAA) and conductive parts of other assemblies inside the host,
- b) if applicable, the PSTN connection traces (TIP and RING) routed through the host system motherboard and any other conductive area (i.e. traces, through holes, SMD pads, copper areas, etc.) on that motherboard,

which use or generate a voltage shown in the table below (values only for secondary circuits):

EN60950:2000 Table 2K / 2L		
Clearance (mm)	Creepage (mm)	Voltage used or Generated by Host or Other cards
1.0	1.5 (2.4)	Up to 125 Vrms or Vdc
2.0	2.5 (4.0)	Up to 250 Vrms or Vdc
2.5	3.2 (5.0)	Up to 300 Vrms or Vdc

The larger distances shown in brackets applies for Pollution Degree 3 environments (where the local environment within the host is subject to conductive pollution or dry non-conductive pollution, which could become conductive due to expected condensation).

The same clearance and creepage distances also apply between TNV3 areas of the card and earth connections inside the host system. Clearance and creepage between primary (mains) and secondary circuits according EN 60950-1:2001, clause 2.10.3.2 table 2H and clause 2.10.4 table 2L.

Minimum distances between primary and secondary circuits (f.g. for mains voltage 230 V_{AC}):

Clearance = 4 mm

Creepage = 5 mm

Failure to maintain these minimum distances would invalidate the approval.

NOTE: For a host or other expansion cards fitted in the host using or generating voltages greater than 300 V (rms or dc), *advice from a competent telecommunications safety engineer must be obtained.*

If these clearance and creepage distances cannot be provided inside the host due to space limitations, a dielectric material may be used as a physical insulation barrier. The dielectric material used in this insulation must have a thickness of at least 0.4mm.

After installation (or implementation) of the Socket Modem inside a host system, it is recommended that a competent telecommunications safety engineer inspects the complete system to ensure that safety compliance is maintained.

(TNV = Telecommunications Network Voltages)

6.3 Considerations for EMC

6.3.1 EMC Compliance (European Countries)

The Socket Modem has been assessed with respect to emission of and immunity to electromagnetic disturbances and has been found to comply with the relevant harmonized standards as defined by the European EMC Directive (89/336/EEC).

These standards are:

- Generic emission standards which refers to
EN 55022:1998 +A1:2000, Class B
- Generic immunity standards which refers to
EN 55024:1998 +A1:2001
EN 61000-6-2:2001 (industrial environment)

6.3.2 Installation in Host Systems (European Countries)

It is assumed that the Socket Modem will only be assembled in host systems that comply with the EMC Directive.

As per definition of the EMC Directive, the card and its host system will constitute an "installation" similar to e.g. a PC card modem installed in a personal computer. Therefore, if the host system complies with the EMC Directive, there should be no need for verifying continued compliance of the complete system.

However, note that it is the responsibility of the professional installer of Socket Modem to ensure that the complete system placed on the market complies with the Directive.