

GSM Socket Modem

AL7024S, AL7024S-3V Series

Designer's Guide

Version 107
Released 14. Dezember 2007



Information provided by xmodus swiss is believed to be accurate and reliable. However, no responsibility is assumed by xmodus swiss for its use, nor any infringement of patents or other rights of third parties which may result from its use. No license is granted by implication or otherwise under any patent rights of xmodus other than for circuitry embodied in xmodus products. Xmodus swiss reserves the right to change circuitry at any time without notice. This document is subject to change without notice. Please read carefully the safety precautions for a terminal based on the AL7024S Socket Modems.

Product names or services listed in this publication are for identification purposes only, and may be trademarks or registered trademarks of their respective companies. All other marks mentioned herein are the property of their respective owners.

© 2007 xmodus swiss GmbH
Printed in Switzerland
All Rights Reserved

Table of Contents

1.	INTRODUCTION	5
1.1	Models Description.....	5
1.2	Summary.....	5
1.3	Product Specifications.....	6
2.	TECHNICAL OVERVIEW	7
2.1	Block Diagramm of G24 GSM Module.....	7
2.2	Supported Interfaces.....	7
3.	HARDWARE INTERFACE	8
3.1	Interface Signals.....	8
3.2	Signal Description.....	8
3.4	Antenna Interface (RF).....	15
3.4.1	RF Connector:.....	15
3.4.2	Antenna Performance Recommendations.....	16
3.4.3	Antenna Installation.....	16
3.4.4	User Operation.....	16
3.5	Internal SIM Card Interface.....	17
3.5.1	SIM Card reader pins supported:.....	17
3.6	SIM Card Mechanical Drawings.....	18
3.7	External SIM Card Interface.....	19
3.7.1	External SIM Card reader pins supported:.....	19
3.7.2	SIM socket pin description:.....	19
3.7.3	SIM Card Reader Integration:.....	20
3.7.4	Layout Restrictions:.....	20
3.8	Audio - Interface.....	21
3.8.1	Speaker-Circuit.....	21
3.8.2	Microphone circuit.....	22
3.8.3	Audio Circuit Design Considerations.....	22
3.9	ON Signal.....	23
3.9.1	Timing Diagram.....	24
3.9.2	Software Reset.....	24
4.	POWER SUPPLY	25
4.1	Power Supply Design.....	25
4.2	Power Supply 5V (5V Models).....	25
4.3	Power Supply 3.3V (3V Models).....	26
4.4	Power Consumption.....	27
4.5	Preferred Regulators.....	28
5.	CONNECTORS AND PERIPHERAL REFERENCE	29
5.1	RF CONNECTOR.....	29
5.2	Microphone.....	29
5.3	Speaker.....	29
5.4	Antenna Cable.....	29
5.5	GSM antenna.....	29
6.	DESIGN GUIDELINES	30
6.1	Electromagnetic Interference (EMI) Considerations.....	30
6.1.1	Grounding.....	31
6.1.2	RF Antenna.....	31
6.2	Manufacturing Considerations.....	32
7.	MODULE DIMENSIONS	33
8.	REGULATORY APPROVALS	34
8.1	Considerations for Regulatory Approvals.....	34
8.1.1	Regulatory Requirements.....	34
8.1.2	Regulatory Statement.....	34
8.2	Safety Precautions.....	35
8.2.1	User Operation.....	35
8.2.2	Antenna Installation.....	35
8.2.3	Antenna care and replacement.....	35
8.2.4	Electronic devices.....	35
9.	APPENDIX A	36
9.1	REFERENCE DOCUMENTS.....	36

List of Tables & Figures

TABLE 3-1. SERIAL TTL SIGNALS	9
TABLE 3-2. SIGNAL DESCRIPTIONS	10
TABLE 3-3. SIGNAL DESCRIPTIONS (CONT'D).....	11
TABLE 3-3. SIGNAL DESCRIPTIONS (CONT'D).....	12
TABLE 3-4. ANALOG ELECTRICAL CHARACTERISTICS	12
TABLE 3-5. DIGITAL ELECTRICAL CHARACTERISTICS	13
TABLE 3-6. ABSOLUTE MAXIMUM RATINGS.....	14
TABLE 3.7 ANTENNA PERFORMANCE RECOMMENDATIONS.....	16
TABLE 3.8. HEADSET SPEAKER OUTPUT AT MAXIMUM VOLUME LEVEL	21
FIGURE 2-1. INTERFACE BLOCK DIAGRAM.....	7
FIGURE 3-1. SERIAL PINOUT.....	9
FIGURE 3-5. SIM CARD READER	17
FIGURE 6-2. MECHANICAL DRAWINGS	33

1. INTRODUCTION

1.1 Models Description

Models	Operating Bands	Interface Connectors	Interfaces / Power
AL7024S	GSM 900/1800 MHz	<ul style="list-style-type: none"> DIL-64 Header (RM2) MMCX RF Connector 	<ul style="list-style-type: none"> RS232 TTL Level SIM Card Interface 5 VDC Power
AL7024S-3V	GSM 900/1800 MHz	<ul style="list-style-type: none"> DIL-64 Header (RM2) MMCX RF Connector 	<ul style="list-style-type: none"> RS232 TTL Level SIM Card Interface 3.3 VDC Power
AL7024E	GSM Quad Band + EDGE	<ul style="list-style-type: none"> DIL-64 Header (RM2) MMCX RF Connector 	<ul style="list-style-type: none"> RS232 TTL Level SIM Card Interface 5 VDC Power
AL7024E-3V	GSM Quad Band + EDGE	<ul style="list-style-type: none"> DIL-64 Header (RM2) MMCX RF Connector 	<ul style="list-style-type: none"> RS232 TTL Level SIM Card Interface 3.3 VDC Power

1.2 Summary

Xmodus AL7024S Socket Modem provides the OEM with a complete E-GSM/GPRS 900/1800Mhz dual-band modem in a compact socket-mountable module.

The compact size and high level of integration of the Socket Modem minimizes real estate and cost for motherboard and box modem applications. Its low power consumption makes it ideal for portable applications such as pocket modems and for a wide variety of embedded control applications. The pin compatibility between the full range of all ALXXXX Series Socket Modems and ISDN Socket TA's allows upgrading and production configurability without hardware changes.

This designer's guide describes the modem hardware. AT commands and S registers are defined in the AT Command Reference Manual.

As a data modem in CSD mode, the AL7024S Socket Modem can receive data at speeds up to 14.4 Kbps and can send data at speeds up to 14.4 Kbps. As a fax modem, the Socket Modem supports Group 3 send and receive rates up to 14.4 kbps and supports Fax Class I and T.30 protocols.

The Socket Modem with Voice features supports Full Rate, Enhanced Rate and Half Rate (FR/EFR/HR). This mode supports applications such as digital telephone answering machine (TAM), voice annotation, audio recording and playback.

The AL7024S Socket Modems supports GPRS Class B and multislots up to Class 10 with coding schemes CS1 to CS4

SMS services are supported in both GSM and GPRS modes.

The AL7024S GSM Socket Modems suites with internal and external SIM Card Readers.

1.3 Product Specifications

Product Features	
Operating systems:	EGSM: 900 MHz GSM: 1800 MHz
Physical Characteristics	
Size:	64.5 x 26.5 mm Socket Modem Form Faktor
Mounting:	Through DIL-64 connectors
Weight:	22 gram
Environmental	
Operation temp.	-20°C to +60° C
Extended temp.	-30°C to +70° C (option)
Storage temp.	-40°C to +85°C
Performance	
Operating Voltage:	3.3V / 5V
Current consumption :	< 2.5 mA @ DRX9 (Idle mode)
Tx power:	<ul style="list-style-type: none"> • 0.8 W, 850 MHz • 2 W, 900 MHz • 1 W, 1800/1900 MHz
Interfaces	
Connectors:	<ul style="list-style-type: none"> • DIL-64 Header (RM2) • RF MMCX
SIM Card:	<ul style="list-style-type: none"> • Local SIM connectivity • 32K SIM • 1.8 / 3.0 V
Serial RS232:	<ul style="list-style-type: none"> • BR from 300 bps to 115 Kbps • Auto BR from 300 bps to 115 Kbps
Data Features	
GPRS:	<ul style="list-style-type: none"> • Multi-slot class 10 (4 down; 2 up) • Max BR 85.6 Kbps • Class B GSM 07.10 multiplexing protocol • Coding scheme CS1-CS4
CSD:	Max BR 14.4 Kbps
SMS:	<ul style="list-style-type: none"> • MO/MT Text and PDU modes • Cell broadcast
FAX Class 1	

Voice Functions
Telephony Digital audio Differential analog audio lines Vocoders EFR/ER/FR/AMR DTMF support Audio control: echo cancellation, noise suppression, side tone and gain control
GSM Supplementary Services
USSD Phase II Call forwarding Call hold, waiting and multiparty Call diverting Missed-call indicator AOC Call barring
Character Set
UTF8 UCS2
Control / Status Indicators
GPRS coverage Wakeup TX enable Reset
Features over RS232
Embedded TCP/IP stack STK Class II
Emergency and Location
FCC E911 Phase II Location Mandate using EOTD
AT Command Set
GSM 07.05 GSM 07.07 Motorola proprietary AT commands
Accessories
Developer Kit Antennas RF Cables

2. TECHNICAL OVERVIEW

2.1 Block Diagramm of G24 GSM Module

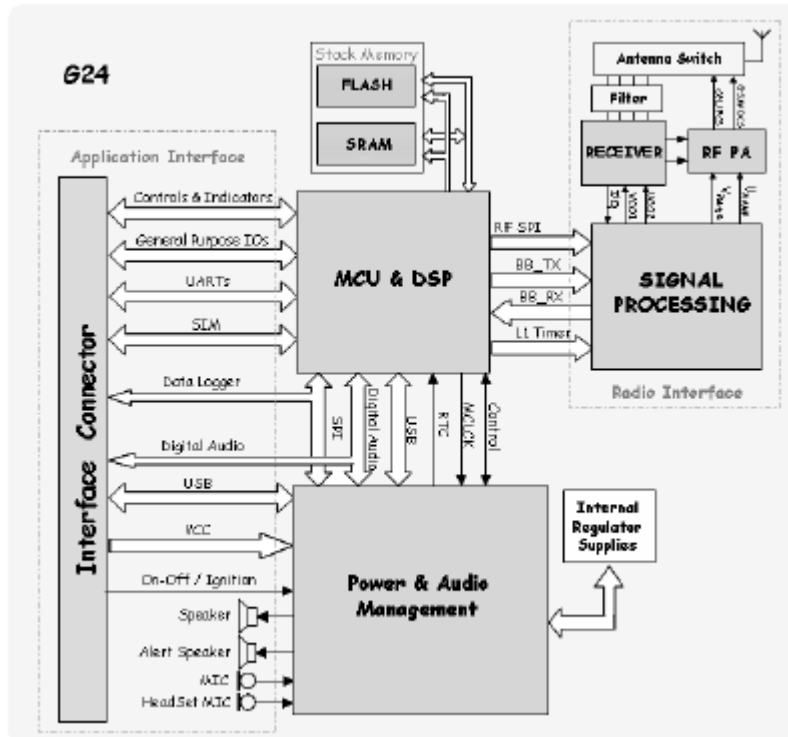

2.2 Supported Interfaces

The major hardware signal interfaces of the DF Series SocketGSM Modem are illustrated in Figure 1-1.

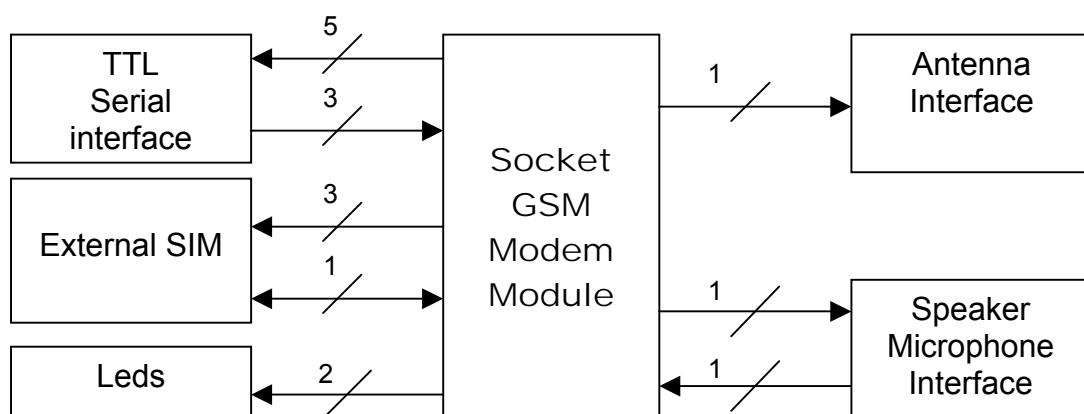

Figure 2-1. Interface Block Diagram

- The RS232 Interface is connected via eight pins to the module.
- The SIM card is connected via 4 pins to the module.
- The Microphone is connected via 2 pins to the module.
- The Speaker is connected via one pin to the module.
- The Indicators are connected via two pins to the module.
- The power supply is connected via one pin to the module.

3. HARDWARE INTERFACE

3.1 Interface Signals

The Socket Modem pin assignments with DTE serial TTL interface, SIM Card and Analog Interface are shown in Figure 3-1 and are listed in Table 3-1.

3.2 Signal Description

The Socket Modem interface signals are described in Table 3-3.

The digital electrical characteristics are listed in Table 3-4.

The analog electrical characteristics are listed in Table 3-5.

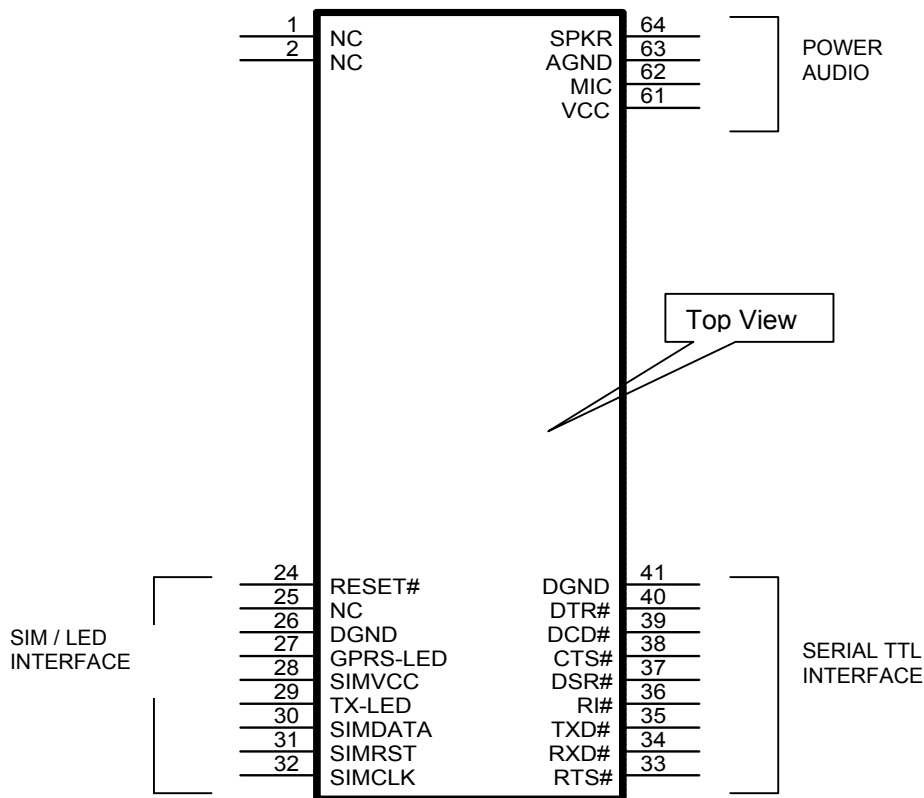

Notes: Pins 3-23 and 42-60 are not installed.

Figure 3-1. SERIAL PINOUT

Table 3-1. Serial TTL Signals

PIN	NAME	I/O TYPE	PIN	NAME	I/O TYPE
1	NC	NC	33	~RTSTTL	Input
2	NC	NC	34	~RXDTTL	Output
3	No pin		35	~TXDTTL	Input
4	No pin		36	~RITTL	Output
5	No pin		37	~DSRTTL	Output
6	No pin		38	~CTSTTL	Output
7	No pin		39	~DCDTTL	Output
8	No pin		40	~DTRTTL	Input
9	No pin		41	DGND	GND Digital
10	No pin		42	No pin	
11	No pin		43	No pin	
12	No pin		44	No pin	
13	No pin		45	No pin	
14	No pin		46	No pin	
15	No pin		47	No pin	
16	No pin		48	No pin	
17	No pin		49	No pin	
18	No pin		50	No pin	
19	No pin		51	No pin	
20	No pin		52	No pin	
21	No pin		53	No pin	
22	No pin		54	No pin	
23	No pin		55	No pin	
24	~RESET	Input	56	No pin	
25	NC	NC	57	No pin	
26	DGND	GND Digital	58	No pin	
27	GPRS LED	Output	59	No pin	
28	SIMVCC	Output	60	No pin	
29	TX LED	Output	61	VCC	POWER +5V
30	SIMDATA	Bi-directional	62	MICV	Input
31	SIMRST	Output	63	AGND	GND Analog
32	SIMCLK	Output	64	SPKR	Output

Table 3-2. Signal Descriptions

Label	I/O Type	Signal Name/Description
VCC	PWR	<p>+5 VDC. A standard 5V +/- 5% - 1.5A power supply is strictly required to supply this module (5V Versions). Chapter 4 should be considered.</p> <p>+3.-3 VDC. A standard 3.3V – 1.5A power supply is strictly required to supply this module (3V Versions). Chapter 4 should be considered.</p>
GND	GND	Digital Ground Connect to Digital Ground on the interface circuit.
~RESET	IC	<p>Module On/Off Signal. Unlike other modems, this signal works as a On/Off switch instead of a standard reset function. The GSM module has already an internal power-up reset circuit. This signal allows to switch off and on the module as a power switch. Special timings must be considered to reliably switching on and off (see chapter 3.9).</p> <p>This signal is active low (on the module is a pull-up resistor of 10K).</p>
AGND	GND	Analog Ground. if a microphone or headset is used, use this as a ground. If these are never used, it can be connected to DGND.

SIM CARD READER INTERFACE		
Label	I/O Type	Signal Name/Description
SIMCLK	O	SIM Clock. Provided from module.
SIMRST	O	SIM Reset. Provided from Module to reset the SIM Card.
SIMDATA	I/O	SIM Data line. Digital, bi-directional data line to exchange data between module and SIM card.
SIMVCC	PWR	SIM Power Supply. 3VDC Power Supply provided from module to power the SIM Card. Only 3V SIM Cards are supported.

Table 3-3. Signal Descriptions (Cont'd)

Label	I/O Type	Signal Name/Description
The Serial interface signals are TTL-level signals.		
~RTSTTL	IB	<p>Request To Send (TTL Active Low). ~RTS is used to condition the local modem for data transmission and, during half-duplex operation, to control the direction of data transmission.</p> <p>On a full-duplex channel, RTS OFF maintains the modem in a non-transmit mode. A non-transmit mode does not imply that all GSM signals have been removed from the link. RTS OFF may be ignored if the modem is optioned to strap ~CTS ON; this allows the modem to receive from the DTE even though RTS is OFF.</p> <p>RTS input ON causes the modem to transmit data on TXD when ~CTS becomes active.</p>
~RXDTTL	OB	<p>Received Data (TTL Active Low). The modem uses the ~RXD line to send data received from the telephone line to the DTE and to send modem responses to the DTE. Modem responses take priority over incoming data when the two signals are in competition for ~RXD.</p>
~TXDTTL	IA	<p>Transmitted Data (TTL Active Low). The DTE uses the ~TXD line to send data to the modem for transmission over the telephone line or to transmit commands to the modem. The DTE should hold this circuit in the mark state when no data is being transmitted or during intervals between characters.</p>
~CTSTTL	OB	<p>Clear To Send (TTL Active Low). ~CTS is controlled by the modem to indicate whether or not the modem is ready to transmit data. ~CTS ON, together with the ~RTS ON, ~DSR ON, and ~DTR ON (where implemented), indicates to the DTE that signals presented on TXD will be transmitted. ~CTS OFF indicates to the DTE that it should not transfer data across the interface on TXD. ~CTS ON is a response to ~DTR ON and ~RTS, delayed as may be appropriate for the modem to establish a connection.</p>
~RITTL	OB	<p>Ring Indicate (TTL Active Low). ~RI output ON (low) indicates the presence of an incoming call.</p>
~DSRTTL	OB	<p>Data Set Ready (TTL Active Low). ~DSR indicates modem status to the DTE. ~DSR OFF (high) indicates that the DTE is to disregard all signals appearing on the interchange circuits except Ring Indicator (~RI).</p>
~DCDTTL	OB	<p>Data Carrier Detect (TTL Active Low). When AT&C0 command is not in effect, ~DCD output is ON when a link is established or OFF when no link is established.</p>
~DTRTTL	IA	<p>Data Terminal Ready (TTL Active Low). The ~DTR input is turned ON (low) by the DTE when the DTE is ready to transmit or receive data. ~DTR ON prepares the modem to be connected and maintains the connection established by the DTE (manual answering) or internally (automatic answering). ~DTR OFF places the modem in the disconnect state under control of the &Dn command. The effect of ~DTR ON and ~DTR OFF depends on the &Dn command.</p>

Table 3-3. Signal Descriptions (Cont'd)

Label	I/O Type	Signal Name/Description
LED driver lines are open-drain inverter-driven (74HCT05) lines with 1.5 K Ω , 1/10W pull-up resistors.		
TX LED	OG	The TX output signal indicates when G24 is transmitting over the GSM network. This signal follows the G24 GSM transmit bursts. This signal is set high during transmission burst, and set low when no transmission is in progress.
GPRS LED	OG	The GPRS output signal indicates the network GPRS/EGPRS connection status. When G24 is connected to a GPRS/EGPRS network, this signal is enabled (set high). When G24 is not connected to the GPRS/EGPRS network this signal is disabled (set low).
Audio/Headset Interface		
MICV	I(DA)	Microphone Voice Input. MICV is a single-ended microphone input from the analog switch circuit. The maximum input to the MICV pin before there is signal distortion in the network is 12mVRMS.
SPKR	O(DF)	Speaker Output. SPKR is a single-ended output.
AGND	PWR	Analog Ground. Analog Ground related to MICV Input.
Notes: 1. I/O types: I(DA) = Analog input (see Table 3-5). O(DD),O(DF) = Analog output (see Table 3-5). IO(DX) = Analog input/output (see Table 3-5).		

Table 3-4. Analog Electrical Characteristics

Name	Type	Characteristic	Value
SPKR	O(DF)	Recommended characteristics for the speaker:	Impedance: 32 Ω (handset) Power: 10mW Sound Pressure.: 110dB
MICV	I(DA)	Recommended characteristics for the microphone:	Bias Voltage: 2.2V (0.5mA) Impedance: 2 KOhms Sensitivity: -40 to -50dB SNR: > 50dB

Table 3-5. Digital Electrical Characteristics

Parameter	Symbol	Min.	Typ.	Max.	Units	Test Conditions
Input High Voltage pins 33,35,40	V_{IH}	2	-	5.5	Vdc	
Input Low Voltage pins 33,35,40	V_{IL}	0	-	0.8	Vdc	
Output High Voltage pins 34,36,37,38	V_{OH}	VCC-0.1V 3.8V @VCC=4.5V	VCC 4.2	- -	Vdc	ILOAD= -20 μ A ILOAD = -4 mA
Output High Voltage VCC=4.5V pin 39	V_{OH}	VCC-0.1 3.8V	VCC -	- -		ILOAD= -50 μ A ILOAD = -8 mA
Output Low Voltage pins 34,36,37,38	V_{OL}	- -	0 0	0.1 0.33	Vdc	ILOAD = 20 μ A ILOAD = 4.8 mA
Output Low Voltage VCC=4.5V pin 39	V_{OL}	- -	- -	0.1 0.44	Vdc	ILOAD = 50 μ A ILOAD = 8 mA
max Reset Low Input Voltage pin 24	V_{IL}	-	-	0.8		internally pulled up to VCC by 10k Ω

Parameter	Conditions	Min	Typ	Max	Unit
SIMDATA V_{IH}	$I_{IH} = \pm 20\mu A$	0.7xSIMVCC			V
SIMDATA V_{IL}	$I_{IL} = 1\text{ mA}$			0.3xSIMVCC	V
SIMRST SIMDATA SIMCLK V_{OH}	Source current = 20 μ A	SIMVCC - 0.1V			V
SIMRST SIMDATA SIMCLK V_{OL}	Sink current = -200 μ A			0.1	V
SIMVCC* Output Voltage	$I_{SIMVCC} \leq 6\text{ mA}$	2.70	2.80	2.85	V
SIMCLK Rise / Fall Time	Loaded with 30pF			50	ns
SIMRST SIMDATA Rise / Fall Time	Loaded with 30pF			1	μ s
SIMCLK Frequency	Loaded with 30pF			3.25	MHz

Table 3-6. Absolute Maximum Ratings

Parameter	Symbol	Min.	Typ.	Max.	Units	Test Condition
Supply Voltage	V_{DD}	-0.3	-	+6.0	Vdc	
Input Voltage	V_{IN}	-0.5	-	+7.0	Vdc	
Nominal Supply Voltage	V_{DD}				Vdc	
5V Version		4.75	-	5.25		
3V Version		3.20	-	3.45		
Static Discharge Voltage	V_{ESD}				V	
@ 25°C		-	+/- 2500			
Operating Temperature Range	T_A				°C	
Operational		-20	-	+60		
Functional		-20	-	+70		
Storage Temperature Range	T_{STG}				°C	
		-40	-	+85		
Supply Current GSM 900	I_D				mA	@ 3.3V
Average multislots (GPRS)			500	550		
Average @PCL5			280	360		
Average @PCL10			170			
Average Idle			30	45		
Sleep mode			2	2,5		
Supply Current GSM 1800	I_D				mA	@ 3.3V
Average multislots (GPRS)			500	550		
Average @PCL5			230	310		
Average @PCL10			170			
Average Idle			30	45		
Sleep mode			2	2,5		
Notes:						
Test Conditions: VCC = 5VDC +/- 5%, TA = 25°C,						

3.4 Antenna Interface (RF)

The AL7024S has two models, one for North America Frequency bands (850/1900 MHz), and one for European Bands (900/1800 MHz). The following connection requirements apply for the AL7024S antenna:

- The AL7024S is terminated with an MMCX connector, and with 50-ohm impedance in the relevant frequencies.
- The AL7024S can be connected to any antenna with 50-ohm impedance in the relevant frequency bands.
- The AL7024S is designed to work on VSWR, up to 3:1 The antenna should meet this requirement.

3.4.1 RF Connector:

The Antenna-jack of the AL7024S module is an MMCX type. It has a snap-in connection. For the antenna-cable RG178 is recommended.

RF Connector	
AL7024S Connector	Mating Connector
Standard MMCX female Amphenol: MMCX 6251S5-3GT30G-50 gold plated	Standard MMCX male (connector for cable)

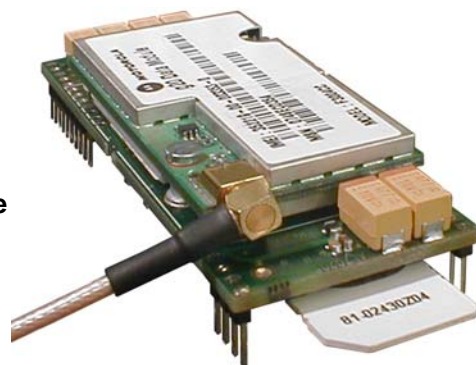

FIGURE 3-4. Antenna Connector Interface

3.4.2 Antenna Performance Recommendations

Table 3.7 - Antenna Performance Recommendations

Frequencies:		
GSM 850	TX	824 – 849 MHz
	RX	869 – 893 MHz
GSM 900	TX	880 – 915 MHz
	RX	925 – 960 MHz
DCS 1800	TX	1710 – 1785 MHz
	RX	1805 – 1880 MHz
PCS 1900	TX	1850 - 1910 MHz
	RX	1930 – 1990 MHz
Gain:	0 dBi (unity) gain or greater	
Impedance:	50 Ohm	
VSWR:	Typical: 1.5:1 Worst case: 2.5:1	

3.4.3 Antenna Installation

- A minimum separation distance of 20 cm needs to be maintained between the antenna and all persons.
- The transmitter effective radiated power must be less than 3.0 Watts ERP (4.9 Watts or 36.9 dBm EIRP). This requires that the combination of antenna gain and feed line loss does not exceed 16 dBi.

3.4.4 User Operation

Do not operate your unit when a person is within 8 inches (20 centimeters) of the antenna. A person or object within 8 inches (20 centimeters) of the antenna could impair call quality and may cause the phone to operate at a higher power level than necessary.

IMPORTANT: The unit must be installed in a manner that provides a minimum separation distance of 20 cm or more between the antenna and persons to satisfy FCC RF exposure requirements for mobile transmitting devices.

IMPORTANT: To comply with the FCC RF exposure limits and satisfy the categorical exclusion requirements for mobile transmitters, the following requirements must be met:

3.5 Internal SIM Card Interface

The AL7024S module has a built-in SIM card reader within the module itself (see figure 3.5). The SIM card is inserted into the slot provided on the side of the connectors (bottom side).

The SIM Interface controls a 3V SIM card. This interface is fully compliant with GSM 11.11 recommendation concerning SIM functions.

3.5.1 SIM Card reader pins supported:

Signal	Pin No	I/O	Description
SIMVCC	1	O	SIM Power Supply
SIMRST	2	O	SIM Reset
SIMCLK	3	O	SIM Clock
SIMGND	5	O	SIM GND
SIMDATA	7	I/O	SIM Data
SIMPRES	8	I	SIM Card Detect not supported

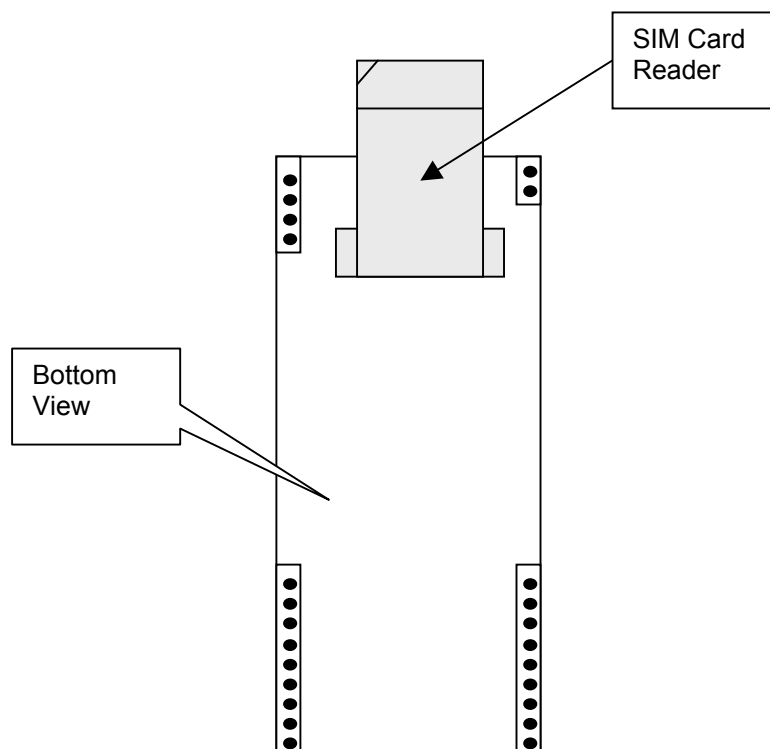
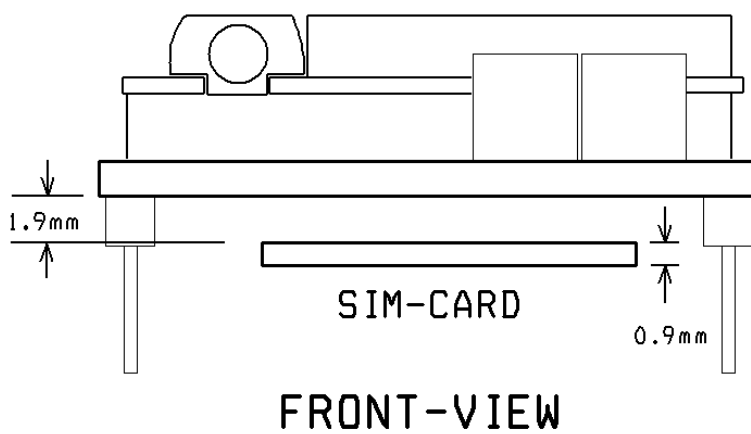
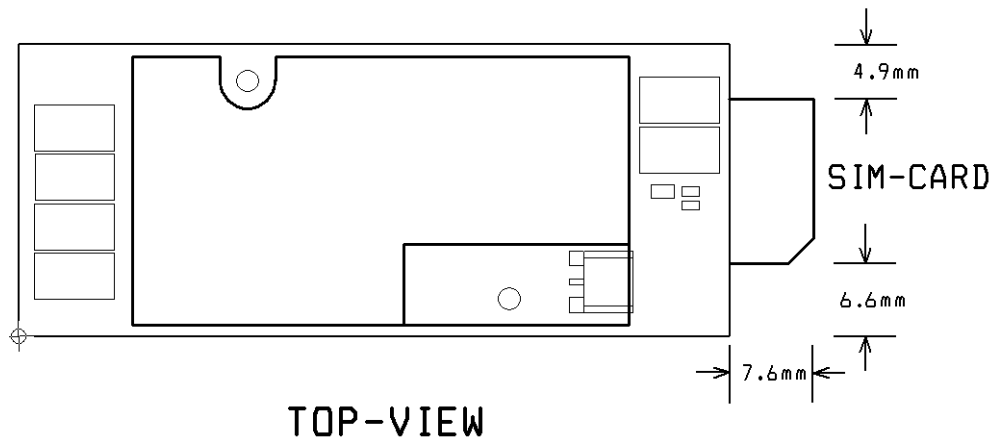

Figure 3-5. SIM CARD READER

3.6 SIM Card Mechanical Drawings

SIM-CARD DRAWINGS



3.7 External SIM Card Interface

4 signals exist:

- SIMVCC: SIM power supply.
- SIMRST: reset.
- SIMCLK: clock.
- SIMDATA : I/O port.

The SIM interface controls a 3V SIM. This interface is fully compliant with GSM 11.11 recommendations concerning SIM functions. It is recommended to add Transient Voltage Suppressor diodes on the signal connected to the SIM socket in order to prevent any Electrostatic Discharge. TVS diodes with low capacitance (less than 10pF) have to be connected on SIMCLK and SIMDATA to avoid any disturbance of the rising and falling edge. These types of diodes are mandatory for the Full Type Approval. They shall be placed as close as possible to the SIM socket.

3.7.1 External SIM Card reader pins supported:

Signal	Pin number	I/O	I/O type	Description
SIMCLK	32	O	2X	SIM Clock
SIMRST	31	O	2X	SIM Reset
SIMDATA	30	I/O	CMOS / 3X	SIM DATA
SIMVCC	28	O		SIM Power Supply

3.7.2 SIM socket pin description:

Signal	Pin Number	Description
VCC	1	SIMVCC
RST	2	SIMRST
CLK	3	SIMCLK
CC4	4	VCC module (Not connected)
GND	5	GROUND
VPP	6	Not connected
I/O	7	SIMDATA
CC8	8	SIMPRES (Not connected)

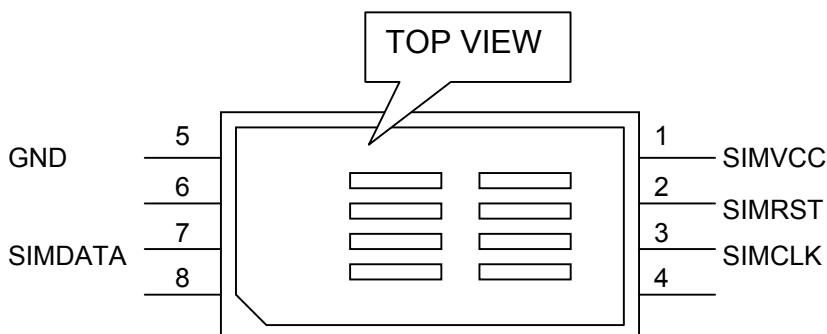

3.7.3 SIM Card Reader Integration:

SIM interface controls a 3V SIM only.

We add Transient Voltage Suppressor (TVS) diodes with low capacitance (less than 10pF) on signal connected to the SIM socket in order to prevent any Electrostatic Discharge. They shall be placed as close as possible to the SIM socket. Following references are used:

DALC208SC6 from ST Microelectronics, which will be connected, to SIMCLK and SIMDATA.

ESDA6V1 from ST Microelectronics for the ESD protection of SIMVCC.

On the board near SIM connector, we also add on SIMVCC a 100nF capacitor in parallel as close as possible to the SIM connector to minimize noise.

Schematic of SIM Interface:

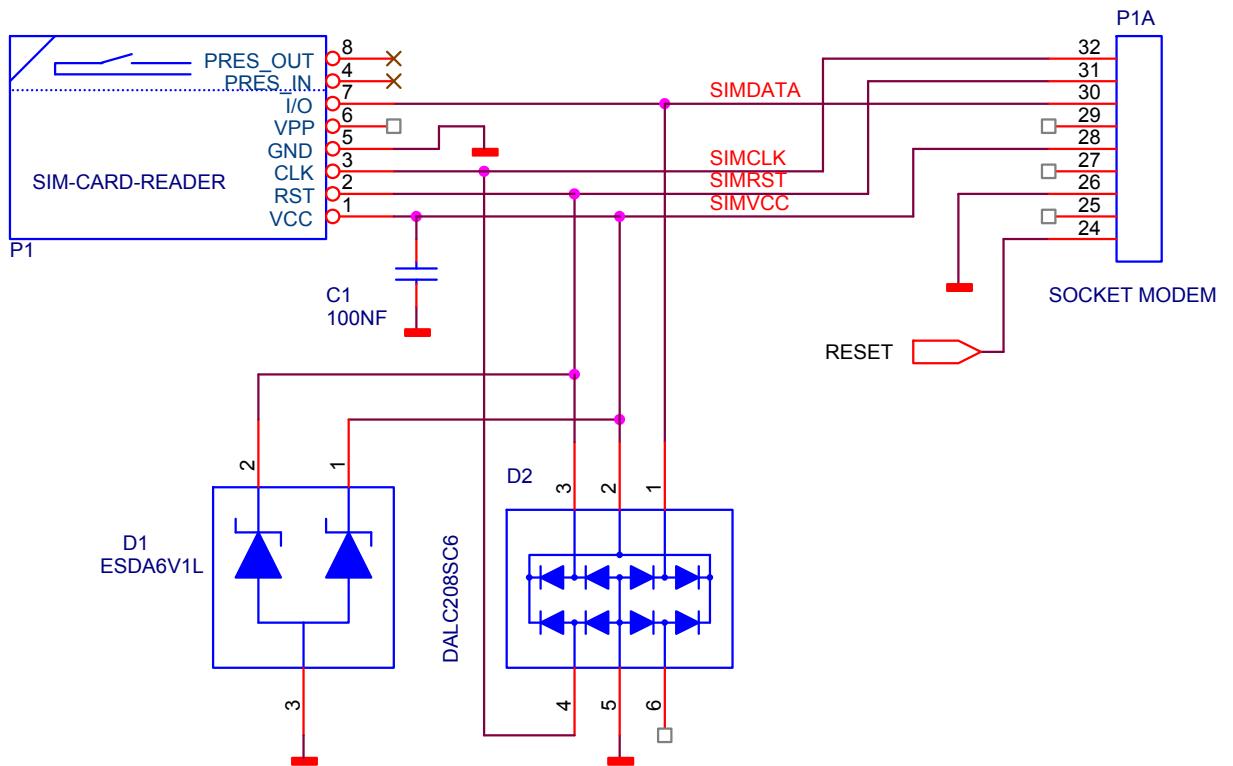

3.7.4 Layout Restrictions:

For the SIM interface, length of the tracks between the GSM modem and the SIM connector should be as short as possible (8cm).

EMI layout is recommended for SIMCLK signal.

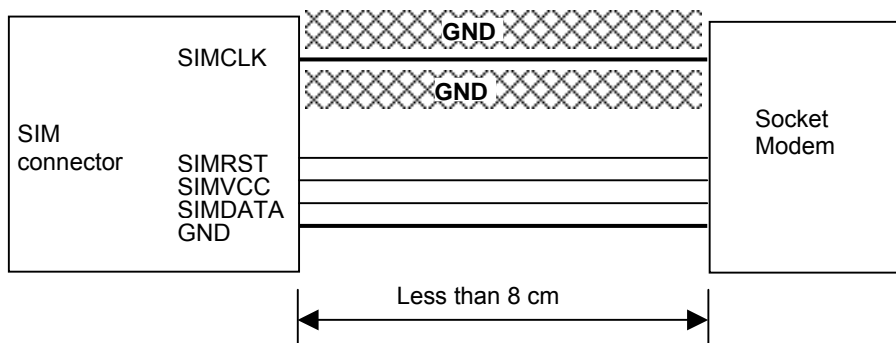

3.8 Audio - Interface

3.8.1 Speaker-Circuit

Audio output is useful for monitoring the modem's call-progress tones and modem system debugging, as well as for fullfeatured Voice applications. You can directly connect a speaker of 32 to 150 Ohms to pins 63 and 64. The connection is single-ended, with analog-ground at pin 63. Use good shielding of the audio-connections as to avoid disturbing performance by entering RF.

The gain of the SPK output is internally adjusted and can be tuned using an AT command. The possible range of output-levels is 4mV to 210mV rms (max. Levels).

Recommended characteristics for the speaker:

- Type: 10mW, electro-magnetic
- Impedance: 32 to 150 Ohms / 1nF (32Ohm for headsets, 150Ohms other applications)
- Sensitivity (SPL): 100dB min
- Frequency response compatible with the GSM specifications

Table 3.8 shows the Speaker output in headset mode for different network signal levels when the g20 is set to the maximum volume level.

Table 3.8. Headset Speaker Output at Maximum Volume Level

dBm0	mV RMS	Headset Speaker (mV RMS)
3.14	1111.9	174
0	774.6	165
-5	435.6	132
-10	244.9	72
-15.5	130	39
-16	122.8	36
-17	109.4	32
-20	77.5	24
-25	43.6	5
-30	24.5	4
max	3000	210

3.8.2 Microphone circuit

The AL7024S has an analog input, referenced to the microphone ground (pin 63). The AL7024S contains an analog amplifier with a default gain of 22dB, which can be adjusted in seven steps between 0 and 31dB using the AT+MMICG command. For more details about this command, refer to the *AT Commands* document (AT_7020A).

When the default gain of 22dB is used, then the level considerations should be as follows:

Pin 62 is the headset microphone input. The input for this line can come directly from a headset microphone. The maximum input to the AL7024S headset microphone before there is signal distortion in the network is 12 mVRMS.

The Microphone ist connected single-ended to pin 62, with analog ground at pin 63. At pin 62 there is also a phantom feeding-voltage of 2.2 Volts.

Recommended characteristics for the microphone:

- 2V – 0.5mA
- KOhms
- Sensitivity -40 to –50dB
- SNR > 50dB
- Frequency response compatible with the GSM specifications

3.8.3 Audio Circuit Design Considerations

In order to design an audio circuit that produces clear audio, without being affected by the GSM transmission, the following guidelines should be considered when designing the circuit:

- The audio input to the AL7024S should be referenced to the MIC GND line of the Module.
- The microphone bias of the AL7024S for the microphone is 2.2 V. If a microphone with a different voltage is used, the bias should be as clean as possible, and referenced to MIC GND. Because most GSM buzz (217Hz TDMA noise) is generated from the microphone path, if a different bias is created, it should be filtered to supply DC only.
- The MIC GND and GND are connected inside the module and should not be connected to the application board.
- Keep the lines of the microphone inputs as short as possible. To filter the lines from RF emission, 39pF capacitors can be used.
- The Module GND should be connected on all pins.
- If possible, the RF cable ground from the AL7024S should be connected to the GND of the Module.
- The digital lines of the application should never be referenced to the MIC GND(63).

3.9 ON Signal

After power is applied to the AL7024S module, the power-on process is initiated, which lasts about five seconds, after which the module is ready to communicate. After power-on, the ON signal is pulled high to the VCC by a 200kΩ resistor. The module remains active until power is turned off or the power-off process is initiated by activating the Reset (ON signal). The AT interface answers "OK" to the application, when the reset is complete.

Turning the G24 Off Using ON Signal

The ON signal is set high using an internal pull up resistor when power is applied to the G24 module. The unit can be turned off only if at least 10 seconds have elapsed since turning it on. Asserting the ON signal low for a minimum of 2 seconds will turn G24 off. This will initiate a normal power-off process, which includes disabling of all applications interfaces (UART, SIM card, audio, etc.) and closing the network connection.

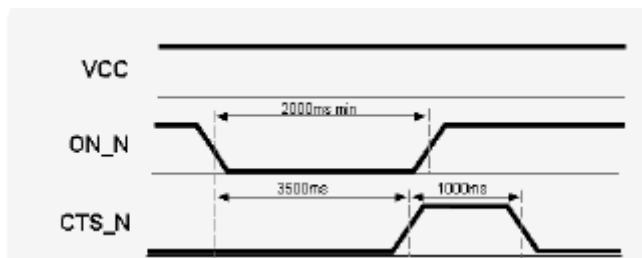

Turning the G24 On Using ON Signal

The ON input signal is set high by an internal pull-up resistor whenever a power supply is applied to the module. Asserting the ON signal low for a minimum of 500 milliseconds (0.5 seconds) and a maximum of 1.5 seconds will cause the G24 to turn-on. Asserting the ON signal low for more than 1.5 seconds may cause the G24 to interpret the signal as a power-off command, and turn off immediately after turning on.

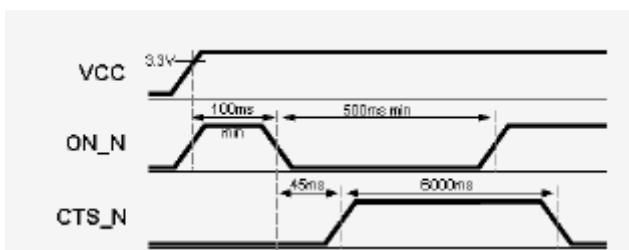

3.9.1 Timing Diagram

Timing diagram for the ON signal.

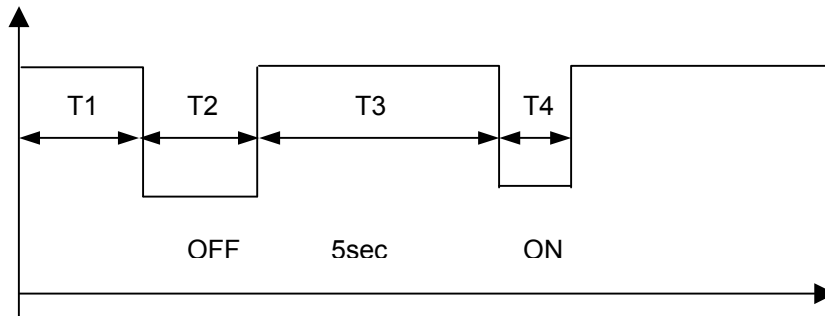

T1: Time from start of application until first OFF signal must be minimum 10 sec. Module is operating and exchanging AT commands in this phase.

T2: Off signal must be 2100ms.

T3: As specified 5s.

T4: Next signal is an ON signal. Must be 1000mS

3.9.2 Software Reset

It is possible to reset the module by software, which activates an internal reset generator (see AT Commands Reference Manual).

4. POWER SUPPLY

The AL7024S power supply must be a single external DC voltage source of 3.3V or 5V (depending on model). The power supply must be able to sustain the voltage level during a GSM transmit burst current surge, which may reach 2.0A.

It is recommended that the user application or usage scenario should avoid power cuts. Especially during the initialization of the unit after power it on. The customer should be following the Designers Guide in respect to the Power supply levels it will receive in order to operate normally.

Table 4-1: Power Supply Signals:

Pin Nr.	Signal name	Description
26, 41	GND	Main ground connection for module.
61	VCC	VIN = 3.3 V or 5 V I _{RMS} = 550 mA during multislotted transmission I _{MAX} = 2 A during transmit bursts

4.1 Power Supply Design

Special care must be taken when designing the power supply of the AL7024S. The single external DC power source indirectly supplies all the digital and analog interfaces, but also directly supplies the RF power amplifier (PA). Therefore, any degradation in the power supply performance, due to losses, noises or transients, will directly affect the AL7024S performance. The burst-mode operation of the GSM transmission and reception, draws instantaneous current surges from the power supply, which causes temporary voltage drops of the power supply level. The transmission bursts consume the most instantaneous current, and therefore cause the largest voltage drop. If the voltage drops are not minimized, the frequent voltage fluctuations may degrade the AL7024S performance.

4.2 Power Supply 5V (5V Models)

A power supply with 5.0V DC +/- 5% (5V models) and a minimum power of 1.5A is strictly required to supply this module. The supply-regulator should be placed as close to the module as possible (about 5cm or nearer). The 5V-trace between regulator and module should be at least 2.5mm wide or better an entire layer.

Important:

The module draws up to 1.3A max. for 577µs every 4,6ms at GSM transmit level PCL5 (2W). Therefore a regulator with fast transient response and good load regulation is strongly recommended.

4.4 Power Consumption

Specifies typical AL7024S current consumption ratings in various operating modes. The current ratings refer to the overall AL7024S current consumption over the VCC supply.

Parameter	Description	Conditions	Min	Typ	Max	Unit
I_{OFF}	RTC mode			75	85	uA
I_{IDLE}	Idle mode			18		mA
I_{SLEEP}	Low power mode	DRx		3.25 2.70 2.45		mA
I_{GSM} (RMS)	Average current GSM voice 1 Tx Slot 1 Rx Slot	GSM850 / EGSM900 PCL DCS1800 / 1900 PCL	5 10 15 19 0 5 10 15	305 165 120 110 225 150 115 107		mA
I_{GPRS} (RMS)	Average current GPRS class 10 2 Tx Slot 3 Rx Slot	GSM850 / EGSM900 PCL DCS1800 / 1900 PCL	5 10 15 19 0 5 10 15	540 275 170 145 345 200 150 140		mA
I_{EGPRS} (RMS)	Average current EGPRS class 10 (EDGE) 2 Tx Slot 3 Rx Slot	GSM850 / EGSM900 PCL DCS1800 / 1900 PCL	8 14 19 2 9 15	339 185 148 260 169 151		mA
I_{GSM} (Max)	Peak current during TX slot	GSM850 / GSM900 PCL DCS1800 / 1900 PCL	5 10 15 19 0 5 10 15	2000 850 430 330 1350 615 380 330		MA
I_{EGPRS} (Max)	Peak current EGPRS Class 10 2 Tx slot 3 Rx slot	GSM850 / EGSM900 PCL DCS1800 / 1900 PCL	8 14 19 2 9 15	1780 635 353 1200 489 367		mA

4.5 Preferred Regulators

Preferred fast response regulators:

The following regulators were tested and found to be good.

- MIC29150	Micrel Inc.	www.micrel.com
- LP3852 / LP3855	National Semiconductor	www.national.com
- LM3940	National Semiconductor	www.national.com
- LTC1778	Linear Technology	www.linear.com

5. CONNECTORS AND PERIPHERAL REFERENCE

5.1 RF CONNECTOR

RF MMCX-connector and accessories can be obtained from

- RADIALL (<http://www.radiall.com/>)
- AMPHENOL (<http://www.amphenol.com/>)
- HUBER&SUHNER (<http://www.hubersuhner.com/>)

5.2 Microphone

Possible references :

- HOSIDEN KUF3323
- HOSIDEN KUF4323
- PANASONIC WM64

5.3 Speaker

Possible references :

- SANYO M15X0080
- PHILIPS
- PRIMO

5.4 Antenna Cable

The following cable reference has been qualified for being mounted on the AL7024S module.

- RG178

5.5 GSM antenna

GSM antennas and support for antenna adaptation can be obtained from manufacturers such as:

- ALLGON (<http://www.allgon.com>)
- MOTECO (<http://www.moteco.com>)
- AMPHENOL (<http://www.amphenol.com>)
- GALTRONICS (<http://www.galtronics.com>)
- RADIALL / LARSEN (<http://www.larsenantennas.com/>)
- RANGESTAR (<http://www.rangestar.com/>)

6. DESIGN GUIDELINES

Good engineering practices must be adhered to when designing a printed circuit board (PCB) containing the GSM Socket Modem module. Suppression of noise is essential to the proper operation and performance of the modem itself and for surrounding equipment.

Two aspects of noise in an OEM board design containing the GSM Socket Modem module must be considered: on-board/off-board generated noise that can affect analog signal levels and analog-to-digital conversion (ADC)/digital-to-analog conversion (DAC), and on-board generated noise that can radiate off-board. Both on-board and off-board generated noise that is coupled on-board can affect interfacing signal levels and quality, especially in low level analog signals. Of particular concern is noise in frequency ranges affecting modem performance.

On-board generated electromagnetic interference (EMI) noise that can be radiated or conducted off-board is a separate, but equally important, concern. This noise can affect the operation of surrounding equipment. Most local governing agencies have stringent certification requirements that must be met for use in specific environments.

Proper PC board layout (component placement, signal routing, trace thickness and geometry, etc.), component selection (composition, value, and tolerance), interface connections, and shielding are required for the board design to achieve desired modem performance and to attain EMI certification.

6.1 Electromagnetic Interference (EMI) Considerations

The EMC tests have to be performed as soon as possible on the application to detect any possible problem. When designing, special attention should be paid to:

- Possible spurious emission radiated by the application to the RF receiver in the receiver band.
- Metallic case or plastic casing with conductive paint are recommended

The following guidelines are offered to specifically help minimize EMI generation. Some of these guidelines are the same as, or similar to, the general guidelines but are mentioned again to reinforce their importance. In order to minimize the contribution of the Socket Modem-based design to EMI, the designer must understand the major sources of EMI and how to reduce them to acceptable levels.

1. Keep traces carrying high frequency signals as short as possible.
2. Provide a good ground plane or grid. In some cases, a multilayer board may be required with full layers for ground and power distribution.
3. Decouple power from ground with decoupling capacitors as close to the Socket Modem module power pins as possible.
4. Eliminate ground loops, which are unexpected current return paths to the power source and ground.
5. Locate high frequency circuits in a separate area to minimize capacitive coupling to other circuits. Distribute high frequency signals continuously on a single trace rather than several traces radiating from one point.

6. Locate cables and connectors so as to avoid coupling from high frequency circuits.
7. If a multilayer board design is used, make no cuts in the ground or power planes and be sure the ground plane covers all traces.
8. Minimize the number of through-hole connections on traces carrying high frequency signals.
9. Avoid right angle turns on high frequency traces. Forty-five degree corners are good, however, radius turns are better

6.1.1 Grounding

Pins 26 and 41 are for grounding. Connect all of them to the same ground-layer or a big ground-area on your board. The ground-area should completely cover the area below and around the module and the regulator. Make the connections as wide as possible. For better RF-performance, connect the metal-housing to ground, very near the ground-pins of the module.

6.1.2 RF Antenna

Antenna sub-system and integration in the application is a major issue. Attention should be paid to :

- Choice of the antenna cable (type, length, performance, thermal resistance, etc)
- Antenna connector (type + losses). These elements could affect GSM performances such as sensitivity and emitted power
- The antenna should be isolated as much as possible from the digital circuitry (including the interface signals)
- It is strongly recommended to shield the terminal.
- On terminals including the antenna, a poor shielding could dramatically affect the sensitivity of the terminal. Moreover, the power emitted through the antenna could affect the application.

Warning:

Xmodus swiss strongly recommends to work with an antenna manufacturer either to develop an antenna adapted to the application or to adapt an existing solution to the application. The antenna adaptation (mechanical and electrical adaptation) is one of the key issues in the design of a GSM terminal.

The antenna-cable and the antenna should be as far as possible away from other circuitry, specially switching-regulators, analog- and uC digital circuits. It is recommended to place the antenna-jack near a metal enclosure and go through this one with the antenna-cable.

6.2 Manufacturing Considerations

The Socket Modem has been designed to be mounted onto the host board in one of two ways.

The first method consists of soldering two 32-pin strip sockets to the host board and inserting the Socket Modem into the sockets. A suggested part number for the 32-pin socket is Sam Tec SMM-132-01-F-S.

The second way is to solder the Socket Modem directly to the host board. The most efficient way to do this is through a wave solder process. The recommended hole size for the Socket Modem pins is 0.036 in. ± 0.003 in. in diameter. Spacers can be used to hold the Socket Modem vertically in place during the wave solder process. A spacer should be placed on pin 32 and pin 64 of the Socket Modem. A suggested part number for the spacer is BIVAR 938-0.130 for P1(0.310in) option Socket Modems. The spacers can be left on permanently and will not effect operation.

Socket Modems can be put through a water wash process.

7. MODULE DIMENSIONS

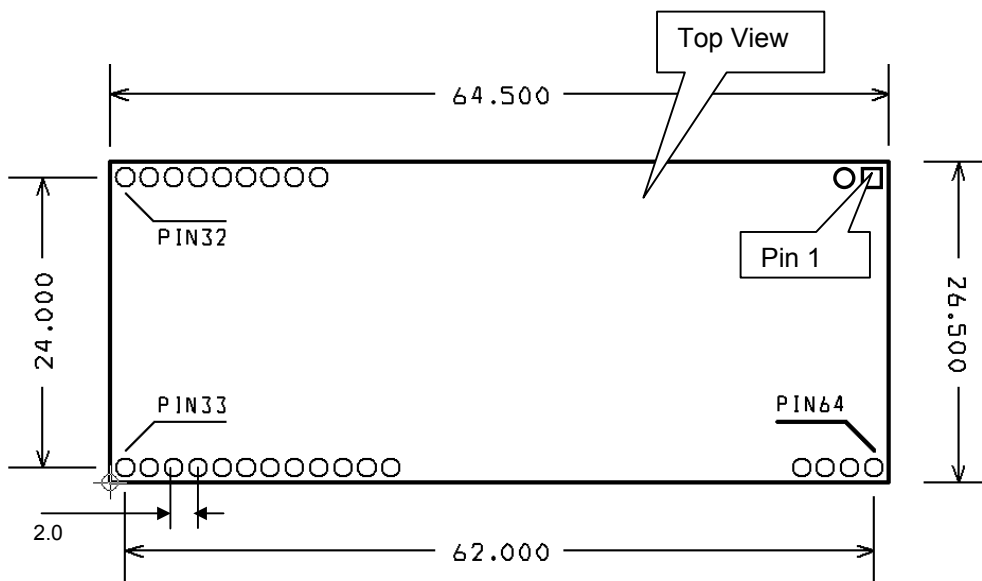
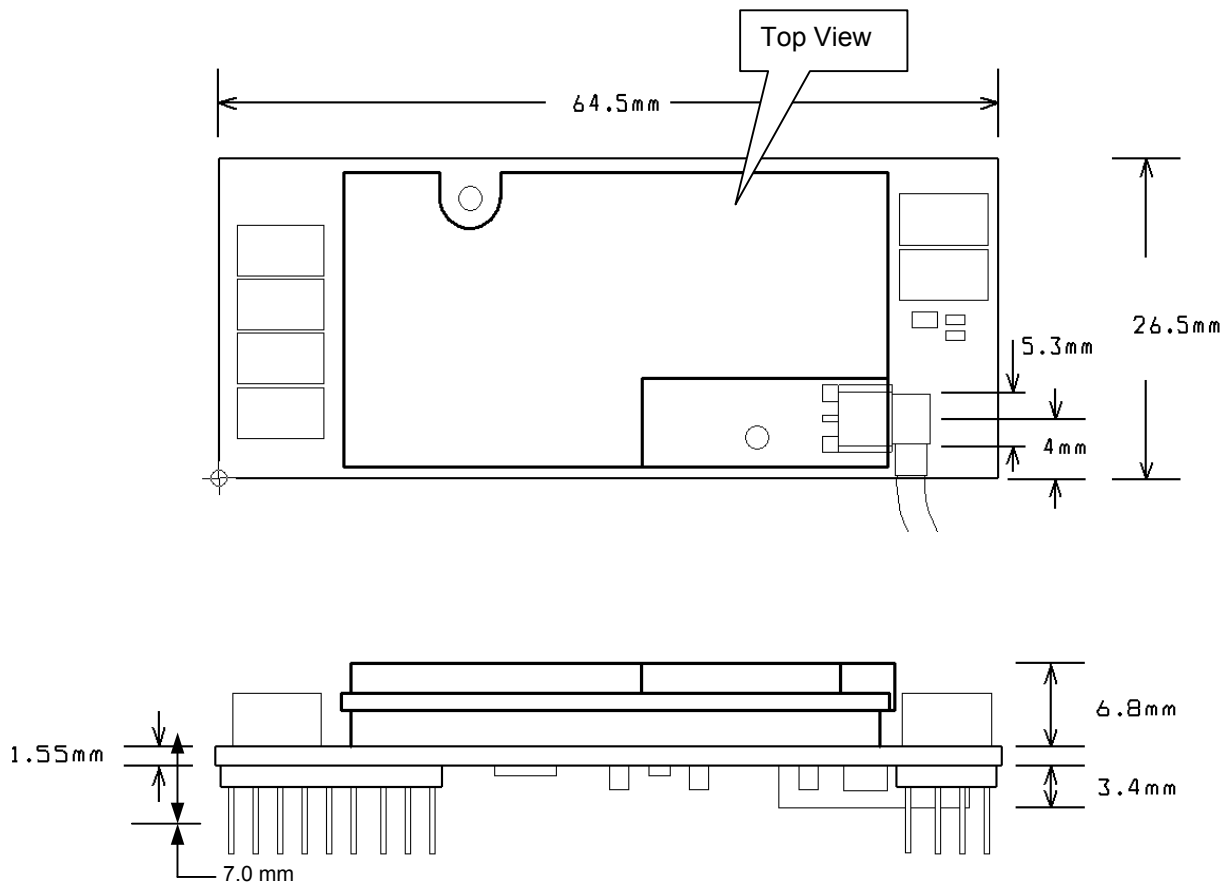

Dimensions in Millimeters

8. REGULATORY APPROVALS

The GSM Socket Modem is approved as a host-independent modem module. To maintain type approvals, permits and/or licenses valid, the guidelines described in this document must be followed.

8.1 Considerations for Regulatory Approvals

The AL7024S Socket Modem has been assessed and has been found to comply with the following regulatory approvals:

- FCC
- DOC
- PTCRB
- R&TTE
- EMC
- GCF

8.1.1 Regulatory Requirements

The Federal Communications Commission (FCC) requires application for certification of digital devices in accordance with CFR Title 47, Part 2 and Part 15. This includes Electromagnetic Energy Exposure (EME) testing. As the AL7024S modem is not a standalone transceiver but is an integrated module, the AL7024S cannot be tested by itself for EME certification. It is, however, the integrator's responsibility to have the completed device tested for EME certification.

8.1.2 Regulatory Statement

The following safety precautions must be observed during all phases of the operation, usage, service or repair of any cellular terminal or mobile incorporating the AL7024S module. Manufacturers of the cellular terminal are advised to convey the following safety information to users and operating personnel, and to incorporate these guidelines into all manuals supplied with the product.

Failure to comply with these precautions violates safety standards of design, manufacture and intended use of the product. Xmodus assumes no liability for customer failure to comply with these precautions.

1. The AL7024S must be operated at the voltages described in the technical documentation.
2. The AL7024S must not be mechanically nor electrically changed. Use of connectors should follow the guidance of the technical documentation.
3. The AL7024S is designed to meet the EMC requirements of ETS 300 342.
4. When integrating the AL7024S into a system, Xmodus recommends testing the system to ETS300342-1.
4. The AL7024S meets the safety requirements of EN60950.
5. Systems using the AL7024S are subject to mandatory EMC testing under directive 89/336/EEC (see item 3 above). Other directives, such as the LVD directive 73/23/EE, may also apply to a system using the AL7024S module.

8.2 Safety Precautions

Your GSM terminal is based on the GSM standard for cellular technology. The GSM standard is spread all over the world. It covers Europe, Asia and some parts of America and Africa. This is the most used telecommunication standard. Your GSM terminal is actually a low power radio transmitter and receiver. It sends out and receives radio frequency energy. When you use your GSM application, the cellular system which handles your calls controls both the radio frequency and the power level of your cellular modem.

8.2.1 User Operation

Do not operate your unit when a person is within 8 inches (20 centimeters) of the antenna. A person or object within 8 inches (20 centimeters) of the antenna could impair call quality and may cause the phone to operate at a higher power level than necessary.

IMPORTANT: The unit must be installed in a manner that provides a minimum separation distance of 20 cm or more between the antenna and persons to satisfy FCC RF exposure requirements for mobile transmitting devices.

IMPORTANT: To comply with the FCC RF exposure limits and satisfy the categorical exclusion requirements for mobile transmitters, the following requirements must be met:

8.2.2 Antenna Installation

A minimum separation distance of 20 cm needs to be maintained between the antenna and all persons. The transmitter effective radiated power must be less than 3.0 Watts ERP (4.9 Watts or 36.9 dBm EIRP). This requires that the combination of antenna gain and feed line loss does not exceed 16 dBi.

8.2.3 Antenna care and replacement

Do not use the GSM terminal with a damaged antenna. If a damaged antenna comes into contact with the skin, a minor burn may result. Replace a damaged antenna immediately. Consult your manual to see if you may change the antenna yourself. If so, use only a manufacturer-approved antenna. Otherwise, have your antenna repaired by a qualified technician. Use only the supplied or approved antenna. Unauthorized antennas, modifications or attachments could damage the terminal and may contravene local RF emission regulations or invalidate type approval.

8.2.4 Electronic devices

Most electronic equipment, for example in hospitals and motor vehicles is shielded from RF energy. However RF energy may affect some improperly shielded electronic equipment.

9. APPENDIX A

9.1 REFERENCE DOCUMENTS

GSM ETSI recommendations for Phase I and Phase II.

Specification Reference	Title
GSM900/1800/1900 ph2 Radio	ETSI GSM 05.05 v7.1.0 release 1998
GSM ph2 Link-Management	ETSI GSM 03.06, 04.08, 05.05, 05.08, 05.10, 07.01 and GT 01 v4.2.1
GSM ph2 Layer 2	ETSI GSM 04.06 and GT 01 v4.2.1
GSM900 ph2 Layer 3	ETSI GSM 04.08 and GT 01 v4.2.1
GSM1800 ph2 Layer 3	ETSI GSM 04.08 and GT 01 v4.2.1
GSM900/GSM1800 Multiband	ETSI GSM 02.07, 03.22, 04.08, 04.13, 05.05, 05.08 and GT 01 v4.2.1
GSM ph2 SIM	ETSI GSM 11.11 and GT 01 v4.2.1
GSM ph2 Teleservices	ETSI GSM 03.50 and GT 01 v4.2.1
GSM ph2 Miscellaneous	ETSI GSM 02.07, 03.40, 03.41, 04.08, 04.10, 04.11, 06.10, 06.11, 06.12, 06.31, 06.32, 07.01, 09.07 and GT 01 v4.2.1
GSM1800 ph2 Miscellaneous	ETSI GSM 02.07, 03.40, 03.41, 04.08, 04.10, 04.11, 06.10, 06.11, 06.12, 06.31, 06.32, 07.01, 09.07 and GT 01 v4.2.1
GSM1900 ph2+	EN 300 919 V7.1.0 (1999-07) European standard (Telecommunications series) Digital cellular telecommunications system (phase2+)